

TR1512-120-60
TR2412-120-60
TR1524-120-60
TR2424-120-60
TR3624-120-60
TR1512-230-50
TR1524-230-50
TR2424-230-50

Installation Manual

Trace Series Inverter/Charger

www.xantrex.com

Smart choice for power



Trace Series Inverter/Charger

Installation Manual

This manual for use by qualified installers only

About Xantrex

Xantrex Technology Inc. is a world-leading supplier of advanced power electronics and controls with products from small mobile units to utility-scale systems for wind, solar, batteries, fuel cells, microturbines, and backup power applications in both grid-connected and stand-alone systems. Xantrex products include inverters, battery chargers, programmable power supplies, and variable speed drives that convert, supply, control, clean, and distribute electrical power.

Trademarks

Trace Series Inverter/Charger is a trademark of Xantrex International. Xantrex is a registered trademark of Xantrex International.

Other trademarks, registered trademarks, and product names are the property of their respective owners and are used herein for identification purposes only.

Notice of Copyright

Trace Series Inverter/Charger Installation Manual © December 2007 Xantrex International. All rights reserved.

Exclusion for Documentation

UNLESS SPECIFICALLY AGREED TO IN WRITING, XANTREX TECHNOLOGY INC. ("XANTREX")

(A) MAKES NO WARRANTY AS TO THE ACCURACY, SUFFICIENCY OR SUITABILITY OF ANY TECHNICAL OR OTHER INFORMATION PROVIDED IN ITS MANUALS OR OTHER DOCUMENTATION.

(B) ASSUMES NO RESPONSIBILITY OR LIABILITY FOR LOSSES, DAMAGES, COSTS OR EXPENSES, WHETHER SPECIAL, DIRECT, INDIRECT, CONSEQUENTIAL OR INCIDENTAL, WHICH MIGHT ARISE OUT OF THE USE OF SUCH INFORMATION. THE USE OF ANY SUCH INFORMATION WILL BE ENTIRELY AT THE USER'S RISK; AND

(C) REMINDS YOU THAT IF THIS MANUAL IS IN ANY LANGUAGE OTHER THAN ENGLISH, ALTHOUGH STEPS HAVE BEEN TAKEN TO MAINTAIN THE ACCURACY OF THE TRANSLATION, THE ACCURACY CANNOT BE GUARANTEED. APPROVED XANTREX CONTENT IS CONTAINED WITH THE ENGLISH LANGUAGE VERSION WHICH IS POSTED AT WWW.XANTREX.COM.

Date and Revision

December 2007 Revision A

Part Number

975-0367-01-01

Product Number

TR1512-120-60, TR2412-120-60, TR1524-120-60, TR2424-120-60, TR3624-120-60, TR1512-230-50, TR1524-230-50, TR2424-230-50

Contact Information

Telephone: 1 800 670 0707 (toll free North America)
1 408 987 6030 (direct)

Fax: 1 800 994 7828 (toll free North America)
1 360 925 5143 (direct)

Email: customerservice@xantrex.com

Web: www.xantrex.com

About This Manual

Purpose

The purpose of this Installation Manual is to provide explanations and procedures for installing the Trace Series Inverter/Charger.

Scope

The Manual provides safety guidelines, detailed planning and setup information, and procedures for installing the inverter. It does not provide details about particular brands of batteries. You need to consult individual battery manufacturers for this information.

Audience

The Manual is intended for use only by qualified installers when installing the Trace Series Inverter/Charger. Installers must be certified technicians or electricians as this manual may not contain all required details and information necessary for a safe and code compliant installation.

Organization

This Manual is organized into two chapters and one appendix.

Chapter 1, “Planning” contains information to pre-plan your installation of the Trace Series Inverter/Charger.

Chapter 2, “Installation” contains information about how to plan for and install the Trace Series Inverter/Charger.

Appendix A, “Specifications” contains information about the electrical, environmental and regulatory specifications of the Trace Series Inverter/Charger.

Conventions Used

The following conventions are used in this guide.



WARNING

Warnings identify conditions or practices that could result in personal injury or loss of life



CAUTION

Cautions identify conditions or practices that could result in damage to the unit or other equipment.

Important: These notes describe things which are important for you to know, but not as serious as a caution or warning.

Model Numbering

This Manual contains information for eight models of the Trace Series Inverter/Charger.

Within this Manual, if information applies to all models of the Trace Series Inverter/Charger then they will be referred to as the Trace Series. If information only applies to select models then the model number will be referenced as shown in the table below. Make sure you know which model Trace Series Inverter/Charger you have purchased.

Model Number	Input Voltage	Power	Battery Bank Operating Voltage	Frequency
TR1512-120-60	120 Vac	1500 VA	12 Volt	60 Hz
TR2412-120-60	120 Vac	2400 VA	12 Volt	60 Hz
TR1524-120-60	120 Vac	1500 VA	24 Volt	60 Hz
TR2424-120-60	120 Vac	2400 VA	24 Volt	60 Hz
TR3624-120-60	120 Vac	3600 VA	24 Volt	60 Hz
TR1512-230-50	230 Vac	1500 VA	12 Volt	50 Hz
TR1524-230-50	230 Vac	1500 VA	24 Volt	50 Hz
TR2424-230-50	230 Vac	2400 VA	24 Volt	50 Hz

Abbreviations and Acronyms

AC	Alternating Current
ASC	Authorized Service Center
COM	Communications Port
DC	Direct Current
PV	Photovoltaic
RE	Renewable Energy
RMA	Return Material Authorization
Trace Series	Trace Series Inverter/Charger

Related Information

You can find more information about Xantrex Technology Inc. as well as its products and services at **www.xantrex.com**.

IMPORTANT SAFETY INSTRUCTIONS

SAVE THESE INSTRUCTIONS

THIS MANUAL CONTAINS IMPORTANT INSTRUCTIONS THAT SHALL BE FOLLOWED DURING INSTALLATION OF ALL TRACE SERIES INVERTER/CHARGER MODELS.



WARNING: Limitations on use



The Trace Series is not intended for use in connection with life support systems or other medical equipment or devices.

General

1. Before installing and using the Trace Series Inverter/Charger, read all instructions and cautionary markings on the Trace Series Inverter/Charger and all appropriate sections of this guide and the Trace Series Inverter/Charger Operation Manual (Part #: 975-0391-01-01). Be sure to read all instructions and cautionary markings for any equipment attached to this unit.
2. This unit is designed for indoor use only. Do not expose the Trace Series Inverter/Charger to rain, snow, or spray.
3. To reduce risk of fire hazard, do not cover or obstruct the ventilation openings. Do not install the Trace Series Inverter/Charger in a zero-clearance compartment. Overheating may result.
4. Transformerless battery chargers are not to be used with this product family due to the possible overheating and damage to the charger.
5. Use only attachments recommended or sold by the manufacturer. Doing otherwise may result in a risk of fire, electric shock, or injury to persons.
6. To avoid a risk of fire and electric shock, make sure that existing wiring is in good condition and that wire is not undersized. Do not operate the Trace Series Inverter/Charger with damaged or substandard wiring.
7. Do not operate the Trace Series Inverter/Charger if it has received a sharp blow, been dropped, or otherwise damaged in any way. If the Trace Series Inverter/Charger is damaged, see the Warranty section.

8. Do not disassemble the Trace Series Inverter/Charger. It contains no user-serviceable parts. See Warranty for instructions on obtaining service. Attempting to service the Trace Series Inverter/Charger yourself will void your warranty and may result in a risk of electrical shock or fire. Internal capacitors remain charged after all power is disconnected.
9. The Trace Series contains more than one live circuit (batteries and AC line). Power may be present at more than one source or from more than one location. To reduce the risk of electrical shock, disconnect both AC and DC power from the Trace Series Inverter/Charger before attempting any maintenance or cleaning or working on any circuits connected to the Trace Series Inverter/Charger. Turning off controls will not reduce this risk.
10. Use insulated tools to reduce the chance of short-circuits when installing or working with the inverter, the batteries, or a PV array.
11. Several diagrams contained within this manual are basic in nature and are included only to depict different installation options. All details may not be shown, and as such, local electrical codes must still be referenced.

Wiring Requirements

1. The Trace Series is designed to be permanently connected to the AC and DC electrical systems. Xantrex recommends that all wiring be done by a certified technician or electrician to ensure compliance with the local and national electrical codes relevant to your installation. It is the responsibility of the installer to ensure that the installation of the Trace Series complies with all relevant electrical codes.
2. All wiring methods and materials shall be in accordance with local electrical codes. When sizing conductors and conduits interfacing to the Trace Series, both shall be in accordance with all state and local code requirements.
3. This product is intended to be installed as part of a permanently grounded electrical system. This is the single point earth ground for the inverter system.
4. Use copper conductors only with insulation rated for 90°C (or higher).
5. The grounds on the Trace Series are marked with this symbol: 
6. The AC voltage and current on the Trace Series is marked with this symbol: 



WARNING Fire Hazard:

Do not install 120 volt AC stand-alone inverters onto 120/240 volt AC multi-branch circuit wiring. This could pose a fire hazard due to an overloaded neutral return wire in this configuration. See the Application Note titled “Multi-wire Branch Circuit Issues” on the Xantrex website for additional information and possible solutions.

Explosive Gas Precautions



WARNING: Explosion Hazard

Working in the vicinity of lead-acid batteries is dangerous. Batteries generate explosive gases during normal operation. Therefore, you must read this guide and follow the instructions exactly before installing or using your Trace Series Inverter/Charger.

1. This equipment contains components which tend to produce arcs or sparks. To prevent fire or explosion, do not install the Trace Series Inverter/Charger in compartments containing batteries or flammable materials, or in locations that require ignition-protected equipment. This includes any space containing gasoline-powered machinery, fuel tanks, as well as joints, fittings, or other connections between components of the fuel system.
2. To reduce the risk of battery explosion, follow these instructions and those published by the battery manufacturer and the manufacturer of the equipment in which the battery is installed.

Precautions When Working With Batteries



WARNING: Explosion or Fire Hazard

Follow all instructions published by the battery manufacturer and the manufacturer of the equipment in which the battery is installed.

1. Make sure the area around the battery is well ventilated.
2. Never smoke or allow a spark or flame near the engine or batteries.
3. Use caution to reduce the risk of dropping a metal tool on the battery. It could spark or short circuit the battery or other electrical parts and could cause an explosion.
4. Remove all metal items, like rings, bracelets, and watches when working with lead-acid batteries. Lead-acid batteries produce a short circuit current high enough to weld metal to skin, causing a severe burn.
5. Have someone within range of your voice or close enough to come to your aid when you work near a lead-acid battery.
6. Have plenty of fresh water and soap nearby in case battery acid contacts skin, clothing, or eyes.
7. Wear complete eye protection and clothing protection. Avoid touching your eyes while working near batteries.

8. If battery acid contacts skin or clothing, wash immediately with soap and water. If acid enters your eye, immediately flood it with running cold water for at least twenty minutes and get medical attention immediately.
9. If you need to remove a battery, always remove the grounded terminal from the battery first. Make sure all accessories are off so you don't cause a spark.
10. Always use identical types of batteries.
11. Never install old or untested batteries. Check each battery's date code or label to ensure age and type.
12. Batteries are temperature sensitive. For optimum performance, they should be installed in a stable temperature environment.
13. Always recycle old batteries. Contact your local recycling center for proper disposal information.

Regulatory

The Trace Series Inverter/Charger is CSA Certified to appropriate US and Canadian standards. The 230 Vac/50 Hz models have been marked with the CE designation for European countries. See "Safety and Electromagnetic Compatibility Specifications" on page A-4 for more detailed information.

The Trace Series Inverter/Charger is intended to be used for residential or commercial applications. Do NOT use this unit for applications for which it is not listed (i.e., land vehicles or marine craft). It may not comply with the safety code requirements or could possibly present other operational or safety hazards.

FCC Information for the User

The Trace Series Inverter/Charger has been tested and found to comply with the limits for a Class B digital device, pursuant to part 15 of the FCC Rules. These limits are designed to provide reasonable protection against harmful interference when the equipment is operated in a residential environment. This equipment generates, uses and can radiate radio frequency energy and, if not installed and used in accordance with this Installation Manual, may cause harmful interference to radio communications. However, there is no guarantee that interference will not occur in a particular installation. If this equipment does cause harmful interference to radio or television reception, which can be determined by turning the equipment on and off, the user is encouraged to try to correct the interference by one or more of the following measures:

- Reorient or relocate the receiving antenna
- Increase the separation between the equipment and the receiver
- Connect the equipment into a circuit different from that which the receiver is connected

Consult the dealer where the equipment was purchased or an experienced radio/TV technician for help.

Contents

IMPORTANT SAFETY INSTRUCTIONS	vii
--	-----

1 Planning

Unpacking and Inspection	1-2
Pre-installation Planning	1-3
Location	1-3
Mounting	1-4
Ventilation	1-4
Tools Required	1-4
Hardware/Materials Required	1-5
Wiring Considerations	1-5
Grounding Considerations	1-6
AC Grounding	1-6
DC Grounding	1-6
Wire Routing	1-6
Electrical Panels and Circuit Breaker Requirements	1-7
AC Distribution Panel (Sub-Panel)	1-7
DC Disconnect	1-7
Battery Considerations	1-7
Battery Location	1-7
Battery Temperature	1-8
Basic Configurations	1-9
Generators	1-11

2 Installation

Inverter Mounting	2-2
DC Wiring	2-5
General DC Grounding Requirements	2-5
DC Circuit Grounding	2-5
Batteries	2-7
Battery Types	2-7
Battery Cable Sizing	2-7
DC Disconnect and Over-current Protection	2-9
Battery Cable Connections	2-10
Connecting the Battery Bank to the Inverter	2-12
Installing a Battery Temperature Sensor	2-13
Using the COM Port	2-14

Contents

AC Wiring -----2-15

 AC Distribution Panel (Sub-panel) Mounting and Conduit Installation -----2-15

 Accessing the AC Terminals -----2-15

 AC Input to the Inverter -----2-18

 AC Output Wiring to the AC Distribution Panel (Sub-panel) -----2-19

 AC Wiring - On-Grid Applications -----2-20

 AC Wiring - On-Grid Application using a Generator -----2-21

 AC Wiring - Off-Grid Applications -----2-22

Series Stacking-----2-24

 DC Wiring -----2-24

 DC Wiring for Two Disconnect Devices -----2-25

 DC Wiring for One Disconnect Device -----2-26

 DC Wiring With a Conduit Box -----2-28

 Battery Connections for Stacked Inverters -----2-29

 AC Wiring -----2-30

 AC Input to Inverters -----2-30

 AC Output from Inverters -----2-31

 Testing Stacked Inverters -----2-33

 Start-up and Test -----2-33

A Specifications

Safety and Electromagnetic Compatibility Specifications ----- A-4

Figures

Figure 1-1	On-Grid Basic Configuration (Utility Backup)-	1-9
Figure 1-2	Off-Grid Configuration - with Renewable Energy Sources-	1-10
Figure 1-3	Charge Rate versus RMS AC Voltage	1-12
Figure 2-1	Dimensions	2-2
Figure 2-2	Mounting on Construction Studs	2-3
Figure 2-3	Mounting on Plywood	2-4
Figure 2-4	DC Wiring	2-6
Figure 2-5	Battery Cable Connections	2-11
Figure 2-6	DC Terminals on the Trace Series	2-11
Figure 2-7	Installing the DC Hardware and Covers	2-13
Figure 2-8	AC Side Cover Panels	2-16
Figure 2-9	AC Terminals for AC Input to the Inverter	2-18
Figure 2-10	AC Terminals for AC output to the Sub-panel	2-19
Figure 2-11	AC Wiring - On-Grid Application	2-20
Figure 2-12	AC Wiring - On-Grid Application using a Generator	2-21
Figure 2-13	AC Wiring - Off-Grid Application using a Generator	2-23
Figure 2-14	DC Side of the Trace Series	2-24
Figure 2-15	DC Wiring with 2 Disconnect Devices	2-26
Figure 2-16	DC Wiring with 1 Disconnect Device-	2-27
Figure 2-17	DC Wiring with a Conduit Box	2-28
Figure 2-18	Battery Connections	2-29
Figure 2-19	AC Side of the Trace Series	2-30
Figure 2-20	AC Wiring - On-Grid Application using Series Stacking	2-32

Tables

Table 1-1	Charge Rate versus RMS AC Voltage	1-11
Table 2-1	Safety Ground Conductor Size (US Installations)	2-5
Table 2-2	Safety Ground Conductor Size (Canadian Installations)	2-6
Table 2-3	Battery Charge Profiles	2-7
Table 2-4	Minimum Recommended Battery Cable Size versus Length	2-8
Table 2-5	Battery Cable to Maximum Breaker/Fuse Size	2-9
Table 2-6	Minimum Recommended Fuse Size	2-10
Table 2-7	Min. Recommended Wire Size, Torque Values, and Max. Output Breaker Size	2-17
Table A-1	Electrical Specifications - 120 Vac/60 Hz Models	A-2
Table A-2	Electrical Specifications - 230 Vac/50 Hz Models	A-3
Table A-3	Environmental Specifications	A-4

1

Planning

Chapter 1, “Planning” contains information to pre-plan your installation of the Trace Series Inverter/Charger.

Unpacking and Inspection

Carefully unpack the inverter/charger from its shipping carton.

Important: The unit weighs 35–45 lb (15.9–20.4 kg) (depending on model). Have additional help available if necessary, to assist in lifting the unit during installation.

Verify all of the items listed below are present. Please call Xantrex Customer Service if any items are missing.

- Trace Series Inverter/Charger
- Battery Temperature Sensor
- 1 3 ft. (0.9 m) Series Stacking Cable (120 Vac/60 Hz models only)
- 1 Red DC terminal cap
- 1 Black DC terminal cap
- 4 × hardware to secure terminal caps
- 3 × lock washers for DC/GND terminals
- 4 × flat washers for DC/GND terminals
- 3 × nuts for DC terminals
- 1 lower AC wiring box
- 1 upper AC wiring box (vented)
- 3 × hardware to secure AC wiring boxes

Save your proof-of-purchase. This is required if the unit should require warranty service.

Save the original shipping carton and packing materials. If the inverter ever needs to be returned for service, it should be shipped in the original carton. This is also a good way to protect the inverter if it ever needs to be moved.

Record the unit's model, serial number and date of purchase in the appropriate fields in section "Information About Your System" on page WA-4 of the Trace Series Inverter/Charger Operation Manual (Part #: 975-0391-01-01).

Important: Due to continual improvement through product updates, photographs and/or illustrations used in this manual may not *exactly* match your unit. Xantrex Technology Inc. reserves the right to update this product without notice or releasing an updated manual when fit, form or function are not affected.

See the Trace Series Inverter/Charger Operation Manual (Part #: 975-0391-01-01) for additional information if necessary.

Pre-installation Planning

**WARNING: Shock hazard**

Installation must only be performed by installers that are certified technicians or electricians as this manual may not contain all required details and information necessary for a safe and code compliant installation.

Important: Before installing and using the Trace Series Inverter/Charger, read all instructions and cautionary markings on the Trace Series Inverter/Charger and all appropriate sections of this guide. Be sure to read all instructions and cautionary markings for any equipment attached to this unit.

Take some time prior to installing the equipment to pre-plan the installation. Location, mounting, and ventilation should be taken into consideration before any cabling can be done.

Location

Inverters contain sophisticated electronic components and should be located in a well protected, dry environment away from sources of fluctuating or extreme temperatures and moisture. Exposure to saltwater is particularly destructive and potentially hazardous.

Locate the inverter as close to the batteries as possible in order to keep the battery cable length short. However, do not locate the inverter in the same compartment as vented batteries. Batteries generate hydrogen sulfide gas which is corrosive to electronic equipment. They also generate hydrogen and oxygen. If accumulated, an arc caused by connecting the battery cables or switching a relay could ignite this mixture. Mounting the inverter in a ventilated enclosure with sealed batteries is acceptable.

**CAUTION: Corrosion Damage**

If the inverter is installed in a location where it is exposed to a corrosive or condensing environment and fails due to corrosion, it will not be covered under warranty.

Important: Inverters can generate RFI (Radio Frequency Interference). Locate any sensitive electronic equipment susceptible to RFI as far away from the inverter as possible. This includes radios and TVs.

Mounting

The keyhole slots must not be used as the only method of mounting. The purpose of the wall mounting requirement is to orient the inverter so that its bottom cover will not allow burning material to be ejected in the unlikely event of an internal fire. Use ¼ in. (6.4 mm) diameter screws or equivalent for mounting. The mounting surface should be capable of supporting twice the weight of the inverter.

Ventilation

Install the inverter in a well ventilated area/enclosure for proper operation. The inverter's thermal shutdown point will be reached sooner than normal in a poorly ventilated environment, resulting in reduced peak power output and surge capability, as well as shorter inverter life.

The inverter contains an internal fan. Ensure the air vents and intakes are not obstructed in any way. Provide a minimum clearance of 6 in. (15 cm) around the top and bottom, plus 12 in. (30 cm) clearance around the sides of the inverter for ventilation.

Tools Required

The following tools may be required to complete this installation.

- #2 Phillips screw driver
- Flat-head screwdriver (Jeweller's type)
- Assorted open-end wrenches
- Socket wrench and fittings
- Multimeter (True rms)
- Hole saw
- Level
- Wire strippers
- Torque wrench
- Electrical tape
- Pencil
- Utility knife

Hardware/Materials Required

The following hardware or materials may be required to complete this installation.

- ❑ 4 ft. x 4 ft. (1.22 m x 1.22 m) sheet of $\frac{3}{4}$ in. (20 mm) plywood or equivalent; or standard construction stud material, for example 2 ft. x 4 ft. (60 cm x 120 cm)
- ❑ #12 wood screws or $\frac{1}{4}$ in. x $1\frac{1}{2}$ in. (6.5 mm x 38 mm) lag bolts or equivalent
- ❑ Conduit and appropriate fittings
- ❑ Wire nuts

Wiring Considerations

This section describes the wiring requirements and considerations. It provides the required wire sizes, recommended lengths for conductors, and disconnect/circuit breaker requirements. All wiring should be made with minimum 90° C copper wire. While 90°C or higher temperature rated wiring may be used, the wire gauge sizing must still be based in accordance with 75°C wiring ampacities from your local electrical code for use in conjunction with typical AC over-current protection. See “Minimum Recommended Battery Cable Size versus Length” on page 2–8 for details.

All wiring and installation methods should conform to applicable electrical and building codes.

Pre-plan the wire and conduit runs.

- The AC terminals accept cable sizes up to #6 AWG (13.6 mm²).
- The DC terminals accept any size cables that use ring terminals with $\frac{5}{16}$ in. (8 mm) holes and a maximum flange width of $1\frac{5}{16}$ in. (33 mm).
- If you intend to stack two 120 V/60 Hz units, consider the length of the provided series stacking cable (3 ft./0.9 m).
- Due to voltage drop considerations, battery-to-inverter cabling should be only as long as required. See Table 2-4, “Minimum Recommended Battery Cable Size versus Length” on page 2–8 to assist you with cable sizing and length.

For maximum safety, run both AC and DC cables in conduit.

Grounding Considerations

AC Grounding

The inverter/charger should be connected to a grounded, permanent wiring system. Neutral and ground conductors should only be bonded at one place, and only one place, in the system, either at the main electrical service panel or the sub panel. The AC input and output circuits are isolated from the enclosure and the system grounding, if required by the appropriate sections of your local electrical code, is the responsibility of the installer.

DC Grounding

The negative battery conductor should be bonded to the grounding system at only one point in the system. See “DC Circuit Grounding” on page 2–5. Consult your local electrical codes for additional information and requirements.

Wire Routing

Determine all wire routes both to and from the inverter and which knockouts are best suited for connecting the AC conduits. Possible routing scenarios include:

- AC input wiring from the main electrical service panel to the inverter/charger (if used)
- AC input wiring from the generator to the inverter/charger (if used)
- DC input wiring from the batteries to the inverter/charger
- AC output wiring from the inverter/charger to the sub-panel
- Battery Temperature Sensor cable from the batteries to the inverter/charger (if used)
- Remote control cable to the inverter/charger (if used)
- DC ground from the batteries to an external ground rod
- Load circuit wiring rerouted from the main service panel to the sub-panel

Check for existing electrical or plumbing prior to making cuts in the walls. Cut holes in the walls at appropriate locations for routing wiring/cables.

Electrical Panels and Circuit Breaker Requirements

The following electrical panels and circuit breakers may be required for this installation.

AC Distribution Panel (Sub-Panel)

Loads backed up by the inverter will need to be rerouted from the main electrical panel to a sub-panel. This can be done several different ways, depending upon the installation. Always refer to electrical codes for safe wiring practices.

DC Disconnect

Install a DC disconnect breaker or fuse in the positive (+) battery line. This breaker protects the DC wiring in the event of an accidental short. Size the breakers/fuses in accordance with the size of the battery cables in accordance with your local electrical codes. Switch this breaker/disconnect OFF whenever servicing the batteries.

Battery Considerations

The Trace Series can support either 12-volt or 24-volt battery banks, depending on the model. The battery voltage **MUST** match the voltage requirements of the inverter. To determine the correct voltage for the system see the table in “Model Numbering” on page iv.

Battery Location

Locate the batteries in an accessible location. Two feet (61 cm) clearance above the batteries is recommended for access to the battery caps. They should be located as close to the inverter as possible without limiting access to the inverter’s disconnects. Install the batteries to the left of a wall mounted inverter for easy access to the DC side of the inverter and shorter cable runs.

For safety and to limit access to the batteries, a lockable, ventilated, battery enclosure or dedicated room should be used. If an enclosure is used, it should be vented to the outside by a 1 in. (25.4 mm) vent pipe located at the top of the enclosure. Install an intake vent at the bottom of the enclosure to promote air circulation. These vents exhaust explosive hydrogen gases and must not be overlooked when designing an enclosure.

The enclosure should be made of an acid resistant material or have a finish that resists acid to prevent corrosion. It should be capable of holding the electrolyte from at least one battery should a leak occur.

Place a layer of baking soda on the shelves to neutralize any acid that may be spilled in the future (lead-acid batteries only).

Enclosures located outside must be rainproof and screened to prevent access by rodents or insects.

Battery Temperature

The battery enclosure should provide a fairly stable temperature for the batteries. If it is installed in a cold environment, insulation should be used to protect the batteries from the cold. The insulation also provides a more consistent temperature and better system performance.

The battery enclosure should not be installed in direct sunlight where the summer sun can overheat the batteries. Locate the enclosure where it will be protected from the afternoon sun and provide vents in the top and bottom of the enclosure to provide air flow. High battery temperatures greatly shortens the life of the batteries.

Basic Configurations

The following illustrations show basic applications for the Trace Series Inverter/Charger. They include the following configurations.

- On-Grid Configuration - Utility Backup
- Off-Grid Configuration with Renewable Energy Sources and a Generator

Consult with your system design for other possible configurations depending on site and code requirements.

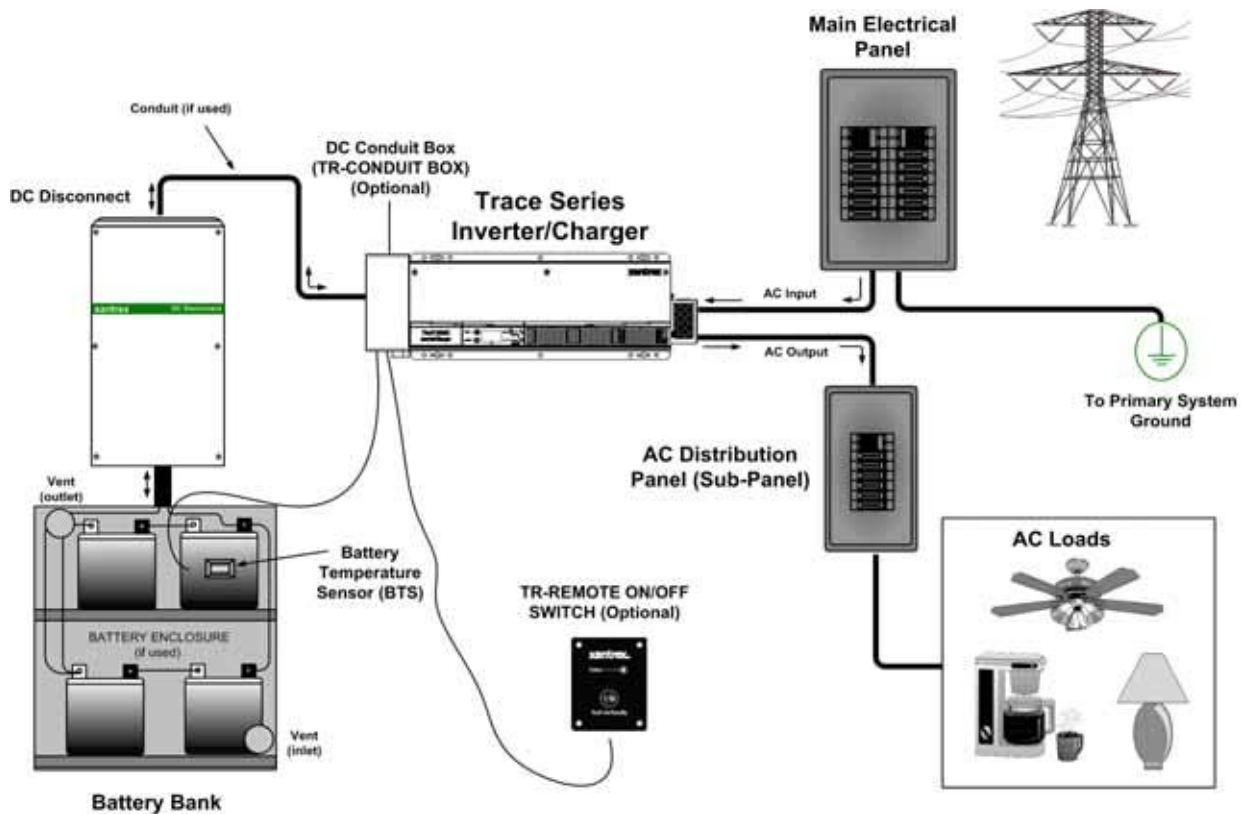

Figure 1-1 On-Grid Basic Configuration (Utility Backup)

Important: For Renewable Energy (RE) sources to be utilized in conjunction with grid power, the inverter's AC input connection to the main electrical panel will need to be switched OFF so the inverter operates in a stand-alone configuration. The utility power can be used like a generator to supply power when the RE sources cannot keep up with the loads.

Renewable Energy (RE) Sources

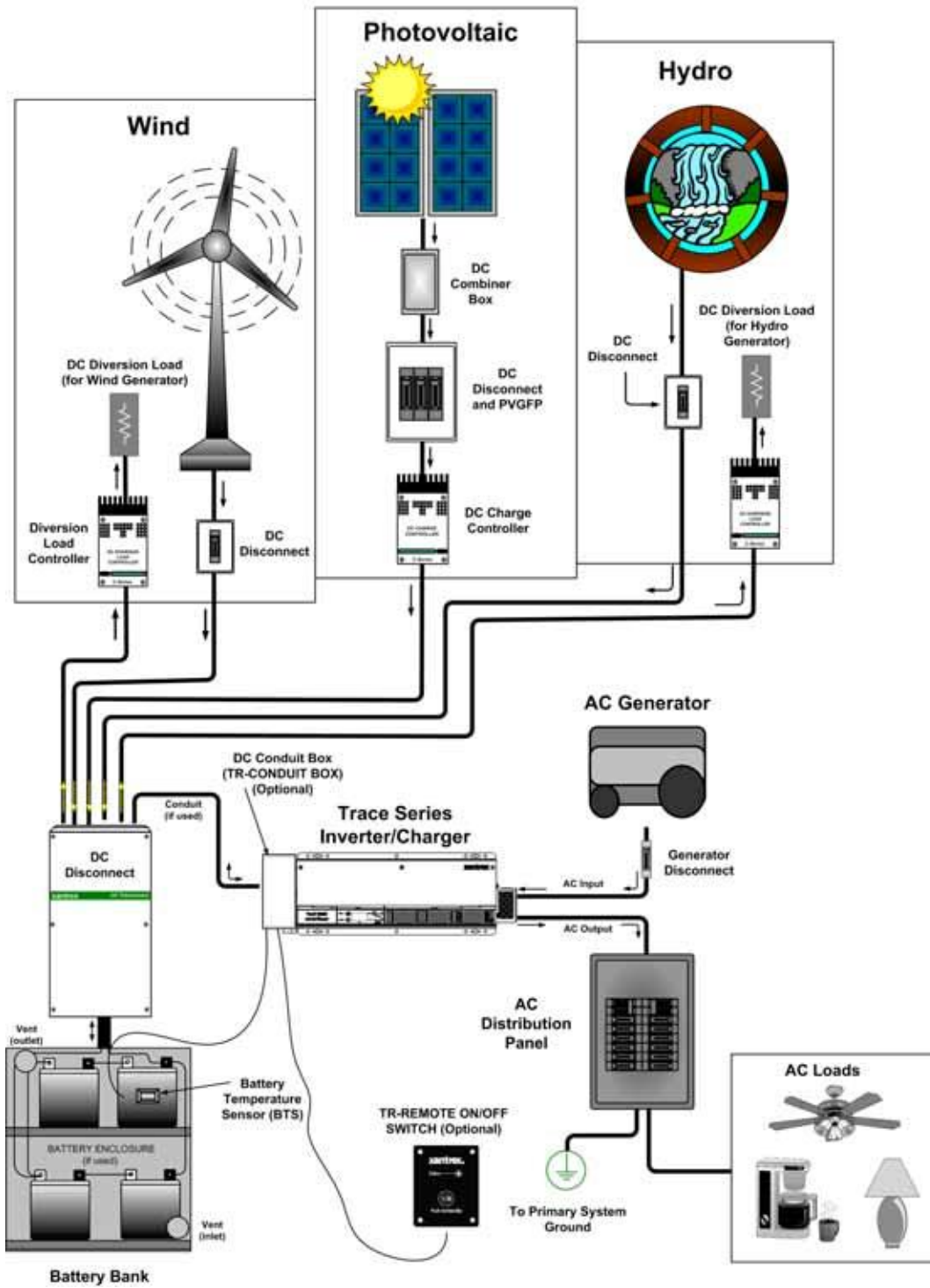

Figure 1-2 Off-Grid Configuration - with Renewable Energy Sources

Generators



WARNING: Shock hazard

Generators utilizing AC outputs with plug/receptacle configurations are not permitted for connection to the AC input terminals of the Trace Series unit. Only the use of generators that are permanently and directly connected to the Trace Series unit, without any type of interconnecting devices, is permitted.

An AC generator can be used as an input source instead of the utility power, or can be connected (using additional hardware) to power the loads when utility is not present (utility outage), and to charge the batteries. The generator must be of the permanently installed type and not a portable type unit used for emergency power (i.e. no cord-connected generators are permitted). Small emergency type (lower power) generators may not have a stable enough voltage for the inverter to synchronize to or provide enough current to fully charge the batteries.

The maximum charge rate the battery charger can deliver is dependant upon the AC voltage available. The charger's rated output is based on a utility voltage of 120 Vac RMS for 120 Vac/60 Hz models and 230 Vac RMS for 230 Vac/50 Hz models.

Size the generator appropriately for the system, including battery charge and load current.

Table 1-1 and Figure 1-3 demonstrates how the AC voltage available affects the charging current.

Table 1-1 Charge Rate versus RMS AC Voltage

RMS AC Voltage Available	TR1512-120-60 TR1512-230-50	TR2412-120-60	TR1524-120-60 TR1524-230-50	TR2424-120-60 TR2424-230-50	TR3624-120-60
70 Vac–90 Vac ^a (134 Vac–180 Vac) ^{ab}	14 amps	20 amps	7 amps	14 amps	14 amps
90 Vac–100 Vac ^a (180 Vac–210 Vac) ^{ab}	35 amps	50 amps	17.5 amps	35 amps	35 amps
100 Vac–110 Vac (210 Vac–240 Vac) ^b	70 amps	70 amps	35 amps	70 amps	70 amps
110 Vac–130 Vac (210 Vac–240 Vac) ^b	70 amps	100 amps	35 amps	70 amps	70 amps
130 Vac–140 Vac (240 Vac–253 Vac) ^b	56 amps	80 amps	28 amps	56 amps	56 amps

a.Charger is OFF for RMS Voltages less than 70 Vac (134 Vac) or greater than 140 Vac (253 Vac).

b.Values in parenthesis are for 230 Vac/50 Hz models.

Planning

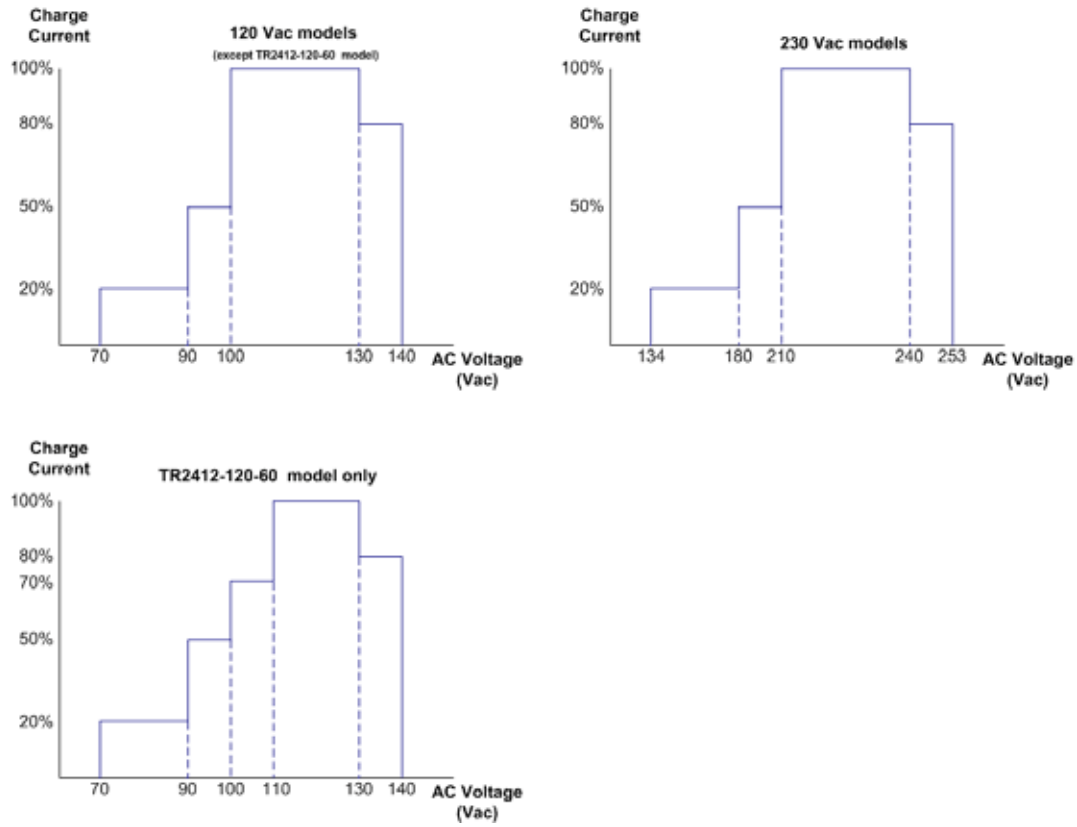

Figure 1-3 Charge Rate versus RMS AC Voltage

2

Installation

Chapter 2, “Installation” contains information about how to plan for and install the Trace Series Inverter/Charger.

Inverter Mounting

The Trace Series inverter can weigh as much as 45 lb. (20.4 kg). Wallboard is not strong enough to support its weight so additional support must be used or added. The inverter can be mounted directly to the wall studs if the wall studs are 16 in. (40.6 cm) apart. If not, then standard size construction stud material, for example 2 ft. x 4 ft. (60 cm x 120 cm) studs or plywood can be used. Ensure a location is selected that can support twice the inverter's weight.



WARNING: Personal Injury

Use appropriate lifting techniques. Have extra people on hand to assist in lifting the inverter into position while it is being secured.

To secure the Trace Series to the wall studs:

1. Locate the studs and mark their location on the wall.
2. Measure the desired height from the floor for the inverter to be mounted.
3. Using a level, mark a horizontal line. The length of the line must span at least three studs.
4. Using the dimensions illustrated in Figure 2-1, drill mounting holes into the center of the studs for the inverter.
5. Secure the inverter to the studs using $\frac{1}{4} \times 1\frac{1}{2}$ in. (6.5 mm x 38 mm) lag bolts and washers or equivalent.

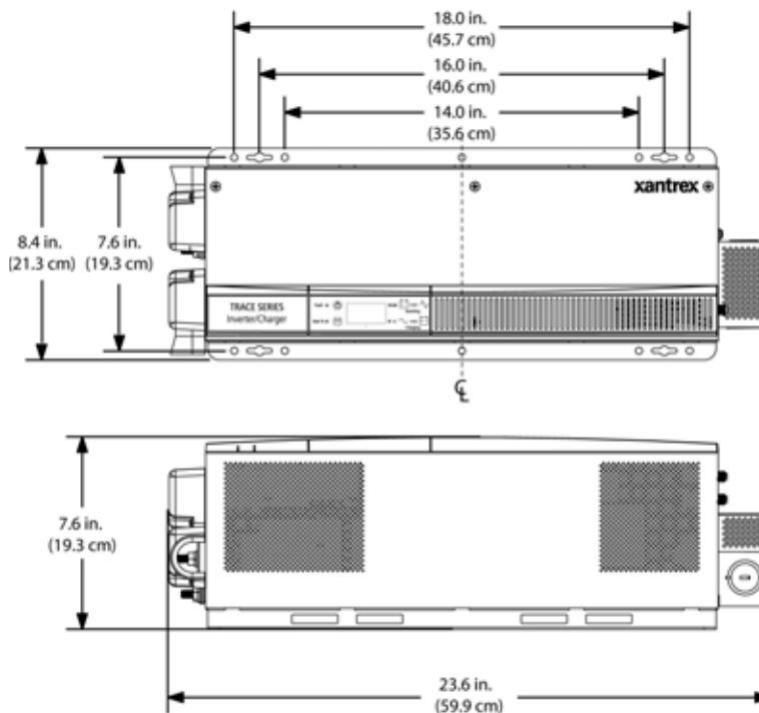

(not to scale)

Figure 2-1 Dimensions

To secure the Trace Series to the mounting location using standard size construction stud material or plywood:

1. Repeat steps 1 through 3 above. See Figure 2-2 and Figure 2-3.
2. Place a pre-cut construction stud (flat side against the wall) on the marked location and drill pilot holes through the construction stud and wall studs.
3. Secure the construction stud with #10 wood screws or equivalent. Wood screw must penetrate 1½ in. (38 mm) into the wall studs as shown in Figure 2-2.
4. Measure 7 5/8 in. (19.4 cm) from the center of the first construction stud and draw another level line. Place the center of the second construction stud over this line and secure to the wall as described in Step 5.
5. Using the dimensions illustrated in Figure 2-1, drill mounting holes into the center of the construction studs for the inverter.
6. Secure the inverter to the construction studs using ¼ x 1½ in. (6.5 mm x 38 mm) lag bolts and washers or equivalent.

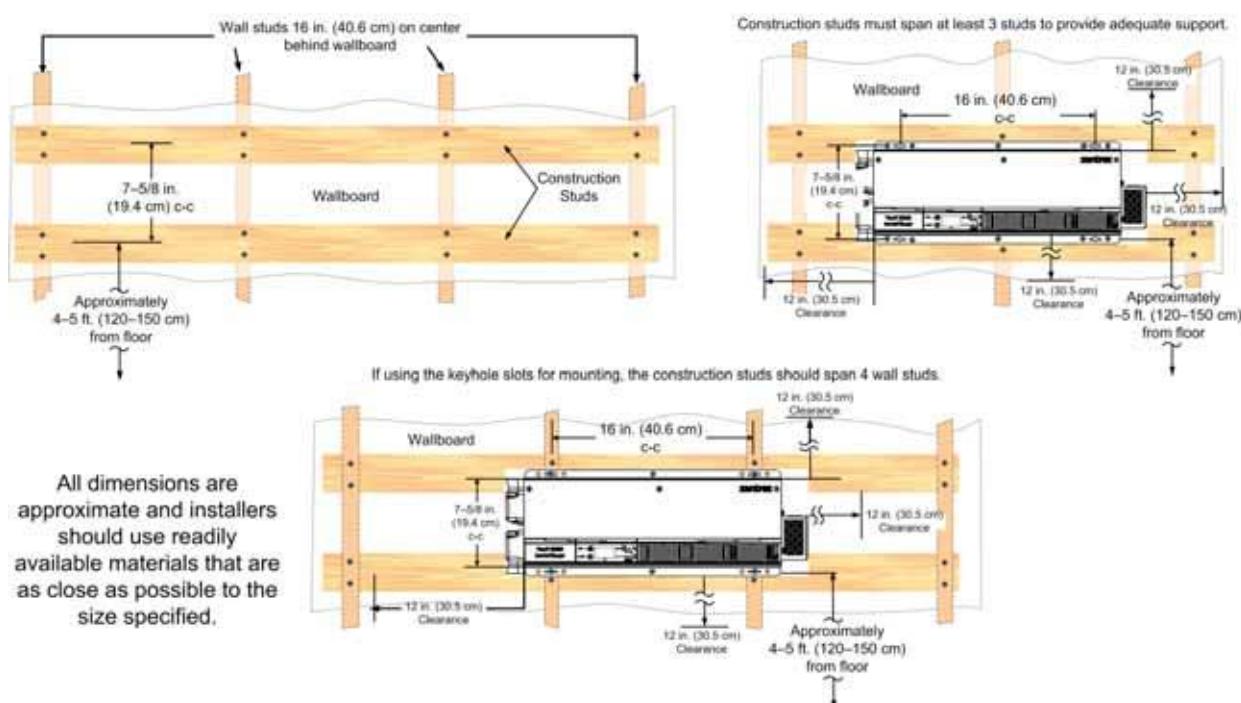

Figure 2-2 Mounting on Construction Studs

All dimensions are approximate and installers should use readily available materials that are as close as possible to the size specified.

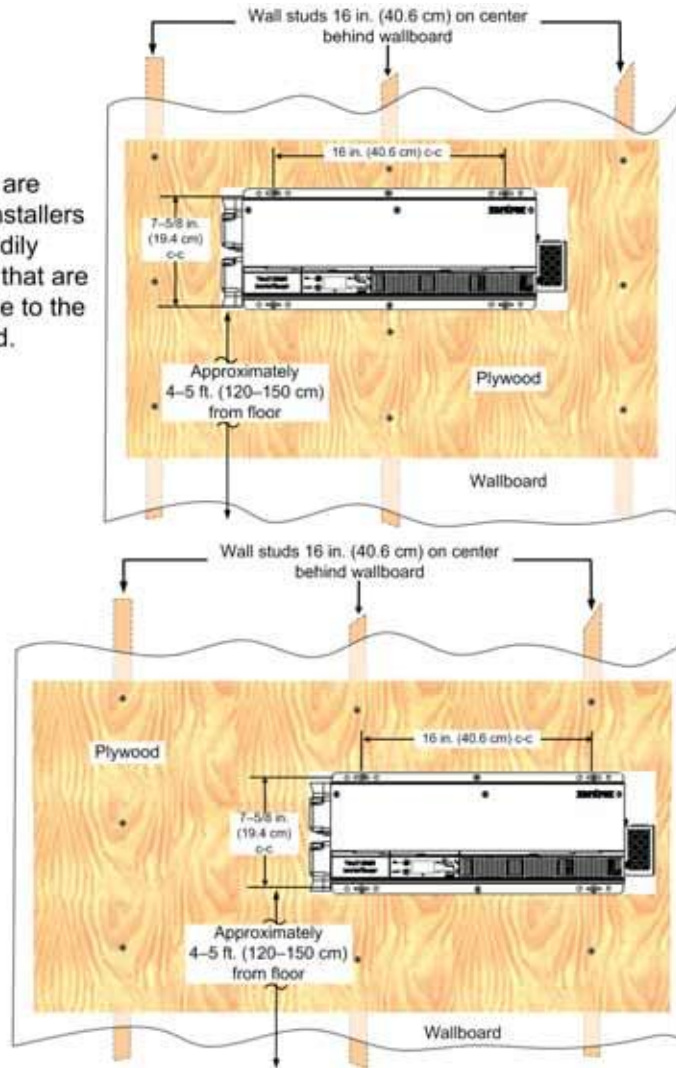

Figure 2-3 Mounting on Plywood

DC Wiring

This section describes the DC wiring requirements and how to make the connections. It provides the required cable and wire sizes, recommended lengths for cables, and disconnect/circuit breaker requirements. All wiring should be made with minimum 90° C wire. The ground lug on the DC end of the Trace Series is 5/16 in. (7.87 mm).

General DC Grounding Requirements

Grounding is an important part of the system installation and must be performed correctly to ensure safe operation of the equipment. Grounding requirements vary by country and application. Consult your local electrical codes for specific requirements.

This product is intended to be installed as part of a permanently grounded electrical system. This is the single point earth ground for the inverter system.

To ground the DC circuits:

1. Connect the negative (-) terminal of the battery bank to an appropriately sized conductor and connect it to the ground bus in the DC Disconnect.
2. Connect an appropriately sized conductor to the Ground bus in the DC Disconnect and connect it to the primary system ground.
3. Torque ground nut to 10-15 in-lb (1.1 - 1.7 Nm).

The system ground is the same ground used by the AC side of the system.

DC Circuit Grounding

The ground conductor should be sized appropriately for the over-current protection device being used. See Table 2-1 and Table 2-2 below for a portion of the NEC and CEC codes). For installations in countries other than the USA and Canada, different local codes and cable sizes may apply.

Table 2-1 Safety Ground Conductor Size (US Installations)^a

Size of Over-current Device Protecting the Conductor	Minimum Size of the Copper Ground Wire
30 to 60 amp	#10 AWG
100 amp	#8 AWG
200 amp	#6 AWG
300 amp	#4 AWG
400 amp	#3 AWG

a. Taken from NEC ANSI/NFPA 70 (2005 Edition) Table 250.122

Table 2-2 Safety Ground Conductor Size (Canadian Installations)^a

Size of Over-current Device Protecting the Conductor	Minimum Size of the Copper Ground Wire
30 amp	#12 AWG
40 or 60 amp	#10 AWG
100 amp	#8 AWG
200 amp	#6 AWG
300 amp	#4 AWG
400 amp	#3 AWG

a. Taken from CEC Part I (2006 Edition), Table 16

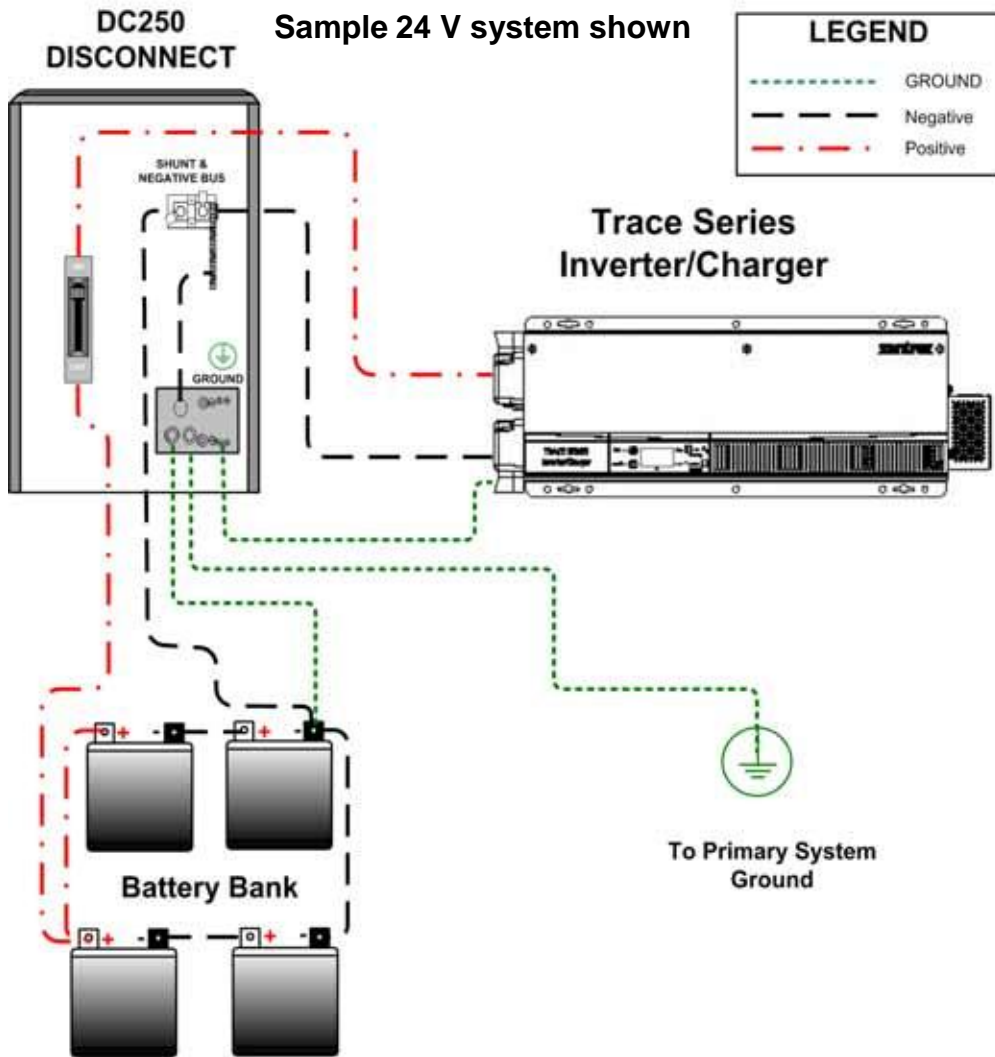

Figure 2-4 DC Wiring

Batteries

The Trace Series can support either 12-volt or 24-volt battery banks depending on the model. Before proceeding, ensure you have the appropriate sized batteries for this inverter. The Trace Series will charge flooded lead-acid, or sealed Gel/AGM lead-acid batteries so ensure that your batteries are in one of these categories.

Table 2-3 Battery Charge Profiles

Profile	Description	Bulk/Absorption		Equalize		Float	
		12V	24V	12V	24V	12V	24V
Flooded	Flooded lead-acid	14.6	29.2	16	32	13.4	26.8
Sealed	Gel/AGM lead acid	14.1	28.2	N/A	N/A	13.5	27.0

Battery Types

Information regarding battery types, battery bank sizing and configuration can be found on the Xantrex website under the Application Note titled "*Battery Banks for Inverter Systems*".

Battery Cable Sizing

Proper cable sizing (diameter and length) is critical to the safe and efficient operation of an inverter system. Larger diameter cables (smaller AWG number) have less voltage drop and are, therefore, more efficient when transferring power to and from the batteries. If a cable is undersized (diameter too small), it could potentially overheat, creating a fire hazard.

Cable length is another important factor. Runs should be kept as short as practical. Longer cable runs increase resistance, thus lowering the overall efficiency of the system. This is especially true in lower voltage systems (i.e., 12 Vdc) where, depending upon the length of the cable run, it may be necessary to oversize the diameter of the wire, or parallel (double) the cables.

Important: Only use copper cables. Always use a properly sized cable and length rated for the amperage of the inverter and batteries.



WARNING: Fire Hazard

Undersized cables can overheat and melt, creating a fire hazard when subjected to heavy (peak) loads.

Table 2-4 provides recommended minimum cable sizes for various cable lengths and inverter amperages. Refer to your local electrical code requirements as recommendations may not meet all codes. The 1 – 5 ft. (30.5 – 152 cm) column refers to the minimum cable sizes for a North American code compliant installation. Cable sizes covering install lengths in excess of 5 ft. (152 cm) are Xantrex recommendations that account for DC voltage drop. DC cable runs in excess of 10 ft. (305 cm) one-way are not recommended.

Important: Run the positive and negative battery cables as close to each other as possible by taping them together. This reduces the effects of inductance and produces a better waveform thus increasing efficiency. See the Application Note titled "*Battery Cable Inductance*" on the Xantrex website.

Table 2-4 Minimum Recommended Battery Cable Size versus Length^a

Inverter Model	Typical Amperage ^b	1 – 5 ft (30.5 – 152 cm) one-way	5 to 10 feet (152 – 305 cm) one-way
TR1512-120-60 TR1512-230-50	165 A	#4/0 AWG (107 mm ²)	350 MCM (177 mm ²)
TR2412-120-60	240 A	350 MCM (177 mm ²)	Not recommended
TR1524-120-60 TR1524-230-50	75 A	#2 AWG (33.6 mm ²)	#1/0 AWG (53.5 mm ²)
TR2424-120-60 TR2424-230-50	120 A	#1/0 AWG (53.5 mm ²)	#2/0 AWG (67.4 mm ²)
TR3624-120-60	175 A	#4/0 AWG (107 mm ²)	350 MCM (177 mm ²)

a. Table 2-4 is based on installation with conduit using no more than three 75°C copper conductors in a maximum 30°C ambient, and then applying the worst case conditions between the CEC Part I 2006 Edition, Table 2 and the NEC ANSI/NFPA 2005 Edition, Table 310.16.

b. At nominal DC voltage and maximum rated power

DC Disconnect and Over-current Protection

For safety purposes and to comply with regulations, battery over-current protection is required. Fuses and disconnects must be sized to protect the wiring in the system and are required to open before the wire reaches its maximum current carrying capability.

The National Electrical Code (NEC) in the US requires both over-current protection and a disconnect switch for residential and commercial electrical systems. Local electrical codes for other countries may also require this and should therefore be referred to during such installations. The over-current protection and a disconnect switch are not supplied as part of the inverter, however, Xantrex offers a DC rated, ETL Listed, circuit breaker disconnect module specifically designed to meet NEC compliance. Two amperage ratings are available: a DC250 (250 amps) and a DC175 (175 amps) in either single or dual breaker configurations for single- or dual-inverter installations.

Important: Xantrex™ DC disconnects are not designed to accept doubled (paralleled) cables which may be required for long cable runs. Also, the plastic red and black covers on the DC inverter inputs are not designed to accommodate dual cables. If dual cables are used, the optional TR-CONDUIT BOX DC conduit box must be used.

Some installations may not require conduit or a disconnect device, although over-current protection is still required. Refer to your local electrical codes for the proper size disconnect device for specific cable diameters. Table 2-5 provides a guideline for selection of appropriate DC over-current protection based on cable size used.

Table 2-5 Battery Cable to Maximum Breaker/Fuse Size^a

Cable Size Required	Rating	Max. Breaker/Fuse Size ^b
#2 AWG (33.6 mm ²)	115 amps	125 amps
#1/0 AWG (53.5 mm ²)	150 amps	150 amps
#2/0 AWG (67.4 mm ²)	175 amps	175 amps (or DC175 breaker)
#4/0 AWG (107 mm ²)	230 amps	250 amps (or DC250 breaker)
350 MCM (177 mm ²)	310 amps	350 amps

a. Table 2-5 is based on installation using no more than three 75°C copper conductors in a maximum 30°C ambient, and then applying the worst case conditions between the CEC Part I 2006 Edition, Table 2 and the NEC ANSI/NFPA 2005 Edition, Table 310.16.

b. Based on available Bussman™ JJN series of Class T fuses.

Important: The NEC allows rounding to the next standard fuse size from the cable rating ONLY when a matching fuse size is not available, otherwise the correct fuse size must be used (i.e. 230 amp cable size rounds up to a standard 250 amp size). Cables enclosed in conduit or raceways have substantially lower continuous current carrying ability, due to heating factors, than those in free air.

In addition to the code required maximum fuse sizes outlined in Table 2-5, Xantrex also recommends the following minimum fuse sizes be used to alleviate the possibility of any nuisance tripping under surge, or other conditions. See Table 2-6 below for details.

Table 2-6 Minimum Recommended Fuse Size

Cable Size Required	Rating
#2 AWG (33.6 mm ²)	100 amps
#1/0 AWG (53.5 mm ²)	150 amps
#2/0 AWG (67.4 mm ²)	150 amps
#4/0 AWG (107 mm ²)	200 amps
350 MCM (177 mm ²)	300 amps

Battery Cable Connections



WARNING: Shock hazard

Ensure the inverter is off and that AC power is disconnected from the inverter input before disconnecting the battery cables.



WARNING: Fire hazard

If you are using fine-stranded DC cables, a corresponding agency approved crimp or compression lug suitable for use with fine-stranded wire must also be used.



CAUTION: Equipment Damage

The inverter is not reverse polarity protected. Reversing the battery polarity on the DC input connections will cause permanent damage to the inverter which is not covered under warranty. Always check polarity before making connections to the inverter.

Battery cables must have crimped (or preferably, crimped and then soldered) copper compression lugs unless aluminum mechanical lugs are used. Soldered connections alone are not acceptable.

Figure 2-5 illustrates the proper method to connect the battery cables to the Trace Series's DC terminals. For installations requiring the use of conduit connections and the corresponding optional TR-CONDUIT BOX DC conduit box, and that have requirements for cable sizes larger than 2/0 AWG (70 mm²) for the DC input wires and 4 AWG (25 mm²) for the chassis ground wire, then right angled lugs must be used.

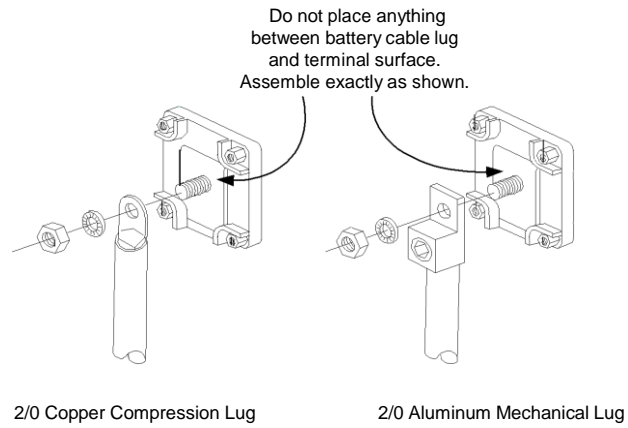

Figure 2-5 Battery Cable Connections

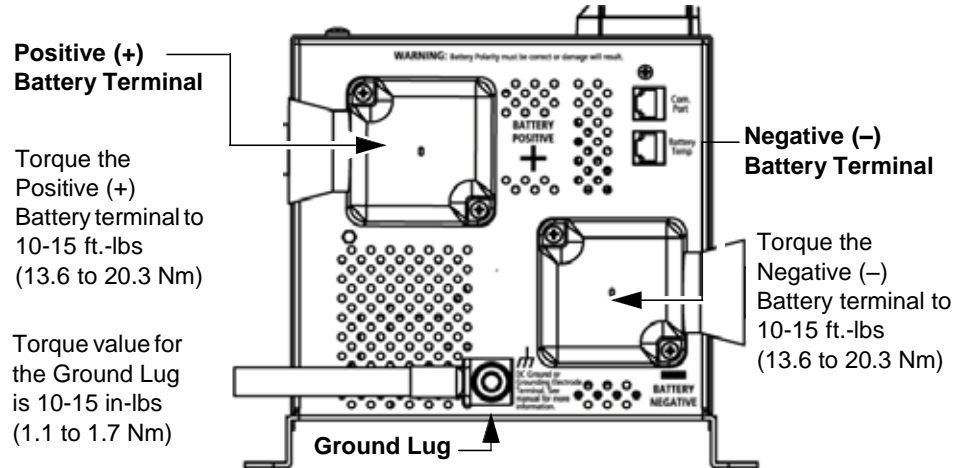

Figure 2-6 DC Terminals on the Trace Series

Connecting the Battery Bank to the Inverter

Use the following procedure to connect the battery bank to the inverter.



WARNING: Shock Hazard

Ensure the inverter is off before connecting or disconnecting the battery cables and that all AC power is disconnected from the inverter's inputs.

To connect the battery bank to the inverter:

1. Determine the correct size battery cable to use for installation from Table 2-4 on page 2-8.
2. Determine the correct size disconnect/fuse for installation as per your local electrical codes.
3. Identify the cables according to your local electrical codes. Ensure you identify both ends of the cable prior to installation.
4. Connect the negative (–) cable to the battery's negative terminal (torque to manufacturer's recommendations).
5. Install the over-current device (fuse or circuit breaker) between the battery's positive terminal and the inverter's positive terminal. Place it as close to the batteries as possible without being installed in the battery enclosure. Consult your local electrical code for any distance requirements of the fuse from the battery source.
6. Connect the (short) positive cable to the battery's positive terminal (torque to manufacturer's recommendations).
7. Ensure the correct polarity of the cables with a DC voltmeter (DVM).
8. Observing battery polarity, connect the positive battery cable (from the over-current device) to the inverter's positive terminal.

Important: The next step may cause a small spark and snapping sound when connecting the cable to the inverter. This is normal and is caused by the inverter's capacitors charging up.

9. Observing battery polarity, connect the negative battery cable to the inverter's negative terminal. See Figure 2-4 on page 2-6.
10. Use an insulated ½ in. wrench or socket to tighten the 5/16 SAE nuts to 10-15 ft.-lb (13.6 to 20.3 Nm) for each inverter input terminal.



CAUTION: Equipment Damage

Do not put anything between the cable ring terminal and the flat metal part of the terminal as overheating of the terminal may occur. Do not apply any type of antioxidant paste until after the battery cable wiring is tightened.

11. Apply antioxidant paste to the battery and inverter terminals.

12. Install the battery terminal connection covers (red for positive, black for negative) over the inverter's DC terminals and secure with the screws and washers provided. Do not over tighten.

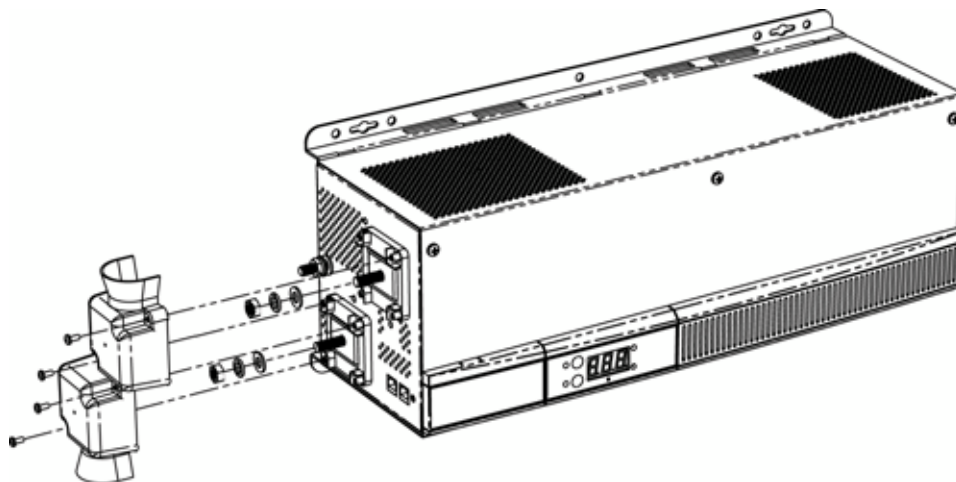

Figure 2-7 Installing the DC Hardware and Covers

Installing a Battery Temperature Sensor

The included battery temperature sensor (Xantrex part #: 808-0232-01) can easily be installed in the system to ensure proper charging of the batteries based on temperature. Installing a battery temperature sensor extends battery life by preventing overcharging in warm temperatures and undercharging in cold temperatures. The information received in this port adjusts the charger's output higher in cold temperatures, assuring the batteries receive a full charge, and lowers it during warm temperatures, reducing battery gassing and providing overcharge protection.

Important: During normal operation, the battery temperature sensor does not disable the charger, it only adjusts charging voltage. The battery temperature does signal the Trace Series to shutdown if it detects temperatures outside of $-20\text{ }^{\circ}\text{C} - 60\text{ }^{\circ}\text{C}$ ($-4\text{ }^{\circ}\text{F} - 140\text{ }^{\circ}\text{F}$).

To install the Battery Temperature Sensor:

1. Connect the RJ11 connector end of the battery temperature sensor wire in to the BATTERY SENSE port located on the DC end of the Trace Series.
If the TR-CONDUIT BOX is used, make sure that the battery temperature sensor cable is correctly routed through the conduit.
2. Secure the sensor to one of the batteries located in the center of the battery bank.

Using the COM Port

The COM port has two different functions. It can either be used to connect a COM cable to provide serial communications to an optional Xantrex remote control unit (TR-REMOTE ON/OFF SWITCH) or it can be used to connect the included series stacking cable for when two Trace Series units are used in a series configuration (see “Series Stacking” on page 2–24). There is one COM port, so you cannot use both stacking interface and remote at the same time.

To use the COM port:

1. Connect one end of the COM cable or series stacking cable in to the COM port located on the DC end of the Trace Series.
If the TR-CONDUIT BOX is used, make sure that the cable is correctly routed through the conduit.
2. Connect the other end of the COM cable into the TR-REMOTE ON/OFF SWITCH remote control unit or connect the other end of the series stacking cable in to another Trace Series unit.

AC Wiring

This section describes the AC wiring requirements and how to make the connections.

AC Distribution Panel (Sub-panel) Mounting and Conduit Installation



WARNING: Shock Hazard

Disconnect the power from the utility's main breaker box before proceeding.

To mount and install the AC distribution panel and conduit:

1. Determine the location of the sub-panel and install it according to the manufacturer's directions.
2. Install the AC conduit between the sub-panel (output) and inverter.
3. Install conduit between the inverter (input) and the main breaker box.
4. Determine which circuits require backup. Install the appropriate branch-rated circuit breakers into the sub-panel.
5. Install an appropriately sized branch-rated circuit breaker in the sub-panel. This will later be wired to the inverter's output. If two inverters are being used in a stacked configuration, install a double-pole circuit breaker for 240 Vac service.

Accessing the AC Terminals



CAUTION: Equipment Damage

The inverter's AC output must never be wired to the utility or generator output. This will cause severe damage to the inverter which is not covered under warranty.

All AC wiring connects to the terminal block located on the right-hand side of the inverter.

To access the AC terminals:

- ◆ Remove the side cover panels (if installed) by removing the three Phillips screws. Units are shipped with the covers uninstalled.

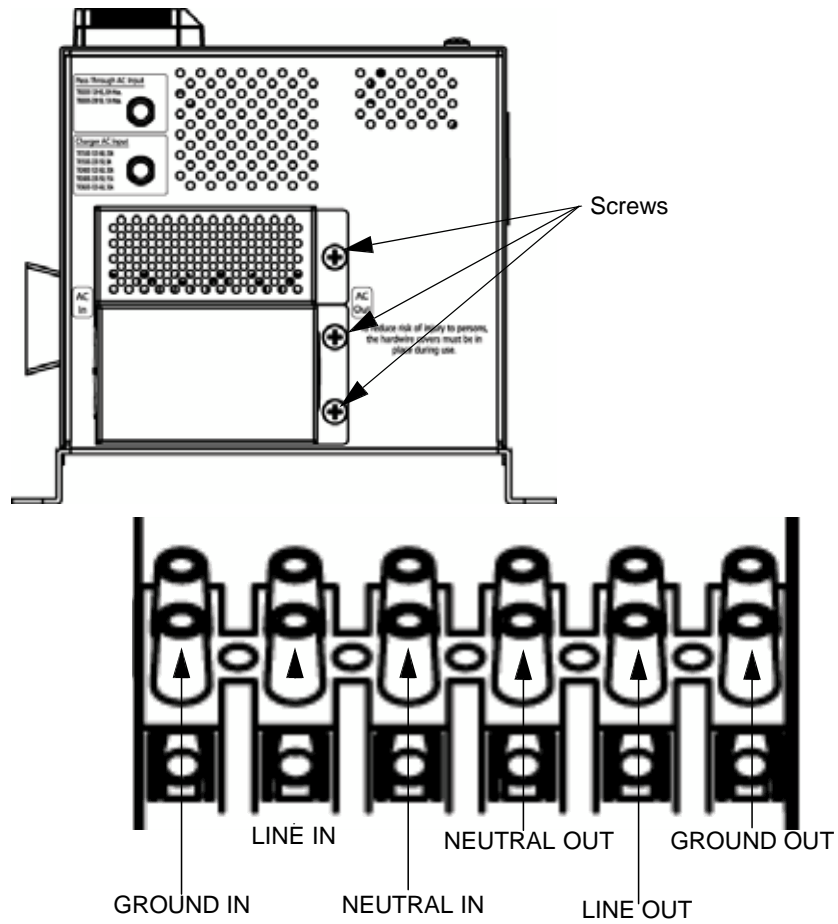

Figure 2-8 AC Side Cover Panels

Before wiring the input of the inverter, refer to Table 2-7 for the minimum recommended wire size.

Important: Refer to your local electrical codes for actual wire sizes for specific installations.

Table 2-7 Min. Recommended Wire Size, Torque Values, and Max. Output Breaker Size^a

Inverter Model	AC Input	AC Output	Torque Value for Terminal Connections	Maximum Output Breaker Size
TR1512-120-60	#6 AWG (13.6 mm ²)	#10 AWG (3.3 mm ²)	16 in-lbs (1.8 Nm) max.	30 amps AC
TR2412-120-60	#6 AWG (13.6 mm ²)	#10 AWG (5.2 mm ²)	16 in-lbs (1.8 Nm) max.	30 amps AC
TR1524-120-60	#6 AWG (13.6 mm ²)	#10 AWG (3.3 mm ²)	16 in-lbs (1.8 Nm) max.	30 amps AC
TR2424-120-60	#6 AWG (13.6 mm ²)	#10 AWG (5.2 mm ²)	16 in-lbs (1.8 Nm) max.	30 amps AC
TR3624-120-60	#6 AWG (13.6 mm ²)	#8 AWG (8 mm ²)	16 in-lbs (1.8 Nm) max.	45 amps AC
TR1512-230-50	#10 AWG (5.2 mm ²)	#14 AWG (2.0 mm ²)	16 in-lbs (1.8 Nm) max.	15 amps AC
TR1524-230-50	#10 AWG (5.2 mm ²)	#14 AWG (2.0 mm ²)	16 in-lbs (1.8 Nm) max.	15 amps AC
TR2424-230-50	#10 AWG (5.2 mm ²)	#14 AWG (2.0 mm ²)	16 in-lbs (1.8 Nm) max.	15 amps AC

a. Table 2-7 is based on installation with conduit using no more than three 75°C copper conductors in a maximum 30°C ambient, and then applying the worst case conditions between the CEC Part I 2006 Edition, Table 2 and the NEC ANSI/NFPA 2005 Edition, Table 310.16.

**WARNING: Fire Hazard**

To reduce the risk of fire, connect only to a circuit provided with the maximum branch-circuit overcurrent protection noted above in accordance with your local electrical codes.

Important: Various local electrical codes require conduit be used in this type of installation. Refer to the local electrical codes (for example, the NEC in the U.S.) to verify if it is needed in your installation. Conduit fittings can be replaced with strain reliefs where code permits.

**WARNING: Shock Hazard**

Disconnect the battery cables from the inverter if they are already connected.

AC Input to the Inverter

To connect the AC Input to the Inverter:

1. Disconnect the main breaker at the main electrical service panel (if used) or disconnect the AC generator.
2. Install an appropriately sized circuit breaker in the electrical service panel. This will serve as both an AC disconnect and over-current protection. If using a generator only, use the circuit breaker in the generator.
3. Feed the line, neutral, and ground wires (using conduit) from the inverter to the AC source. Leave several inches/centimeters of extra wire at each end.
4. Make the connections to the inverter first. Wiring to the AC source is performed after all connections have been made in the inverter.
 - a) Connect the ground wire to the inverter's ground IN terminal.
 - b) Connect the neutral wire from the AC source to the inverter's neutral IN terminal.
 - c) Connect the line wire from the AC source to the inverter's LINE INPUT terminal.
5. Torque all connections to 16 in-lbs (1.8 Nm) max.

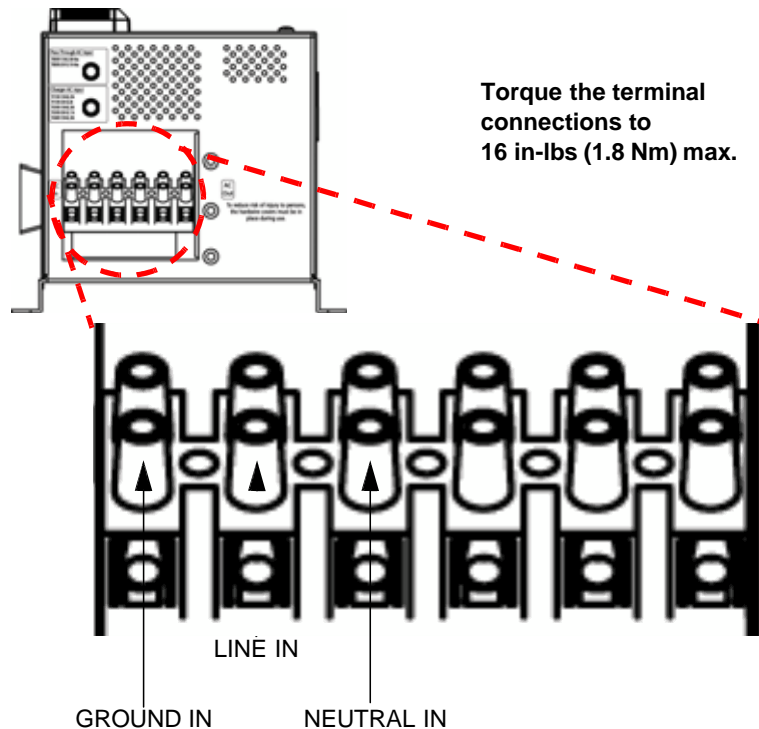

Figure 2-9 AC Terminals for AC Input to the Inverter

AC Output Wiring to the AC Distribution Panel (Sub-panel)



WARNING: Shock hazard

The ground and neutral must be bonded at one place, and only one place, in the system.

To connect the AC output wiring to the sub-panel:

1. Connect the neutral wire to the inverter's neutral OUT terminal. Connect the other end of this wire to the neutral bus in the sub-panel.
2. Connect the line wire to the inverter's line OUT terminal. Connect the other end of this wire to the sub-panel's input circuit breaker.
3. Torque all inverter terminal block connections to 16 in-lbs (1.8 Nm) max.
4. Refer to the sub-panel manufacturer's specifications for wire torque requirements to sub-panel terminals.

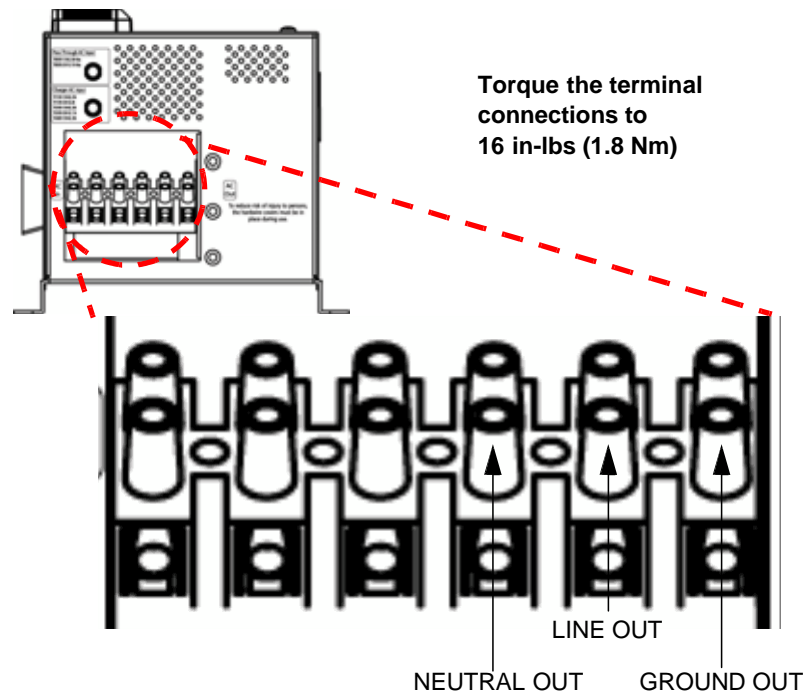

Figure 2-10 AC Terminals for AC output to the Sub-panel

Important: The two neutral connections (input and output) are common to one another and, if necessary, may be used in any combination.

The two ground connections (input and output) are common to one another and, if necessary, may be used in any combination. It may not be necessary to use both ground connections in your installation.

AC Wiring - On-Grid Applications

The following diagrams illustrate the AC wiring for basic configurations. Consult your system design for other possible configurations.

- Figure 2-11, “AC Wiring - On-Grid Application” on page 2–20
- Figure 2-12, “AC Wiring - On-Grid Application using a Generator” on page 2–21
- Figure 2-20, “AC Wiring - On-Grid Application using Series Stacking” on page 2–32

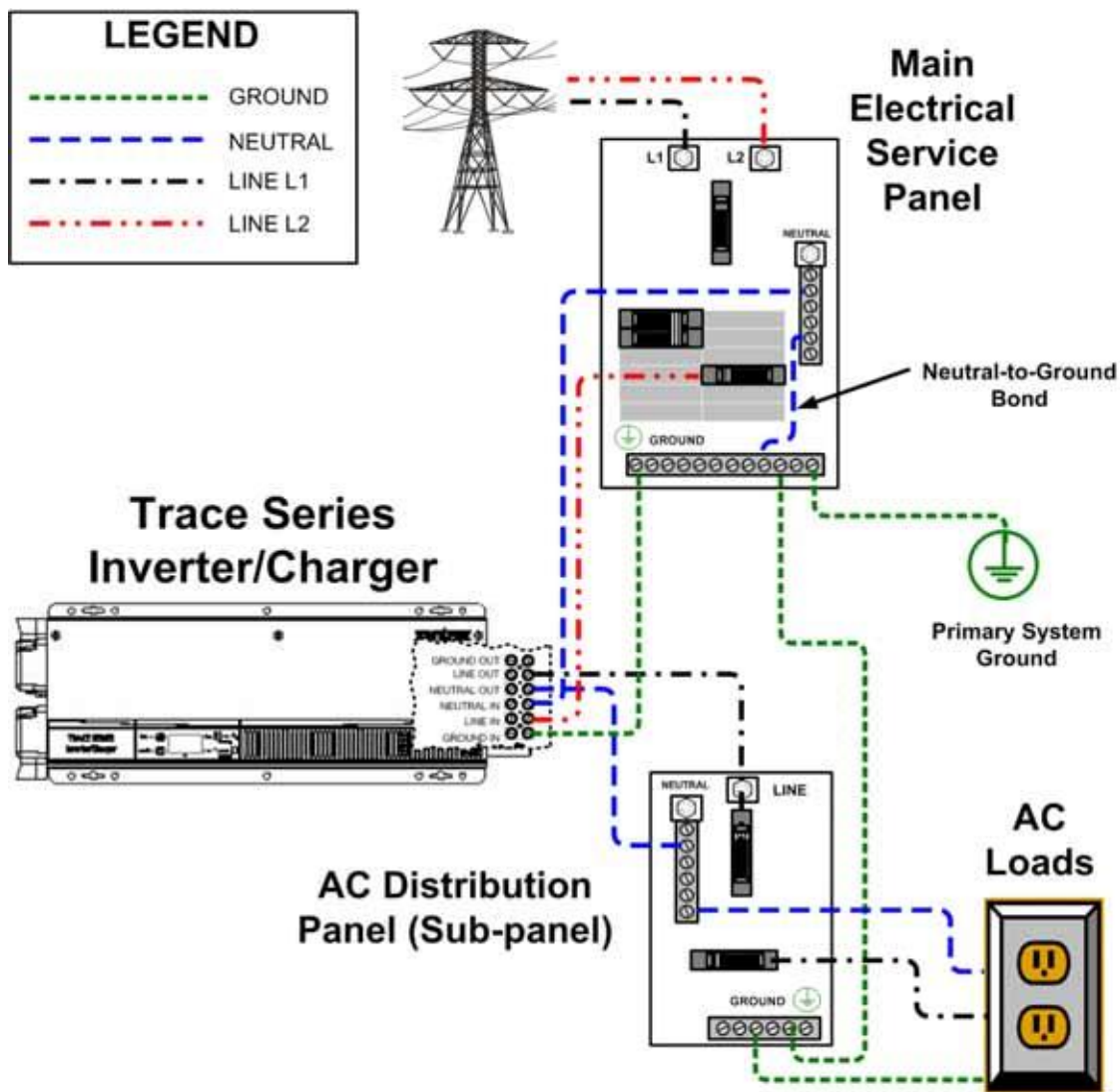

Figure 2-11 AC Wiring - On-Grid Application

AC Wiring - On-Grid Application using a Generator

If a generator is used as a backup for the utility, then a manual or automatic transfer switch must be added to provide a means to switch the generator power to the inverter's input. The generator can be used during extended outages to recharge the batteries and provide pass through power for the loads. Start and stop the generator manually using the generator's pull-cord, ON/OFF switch, etc.

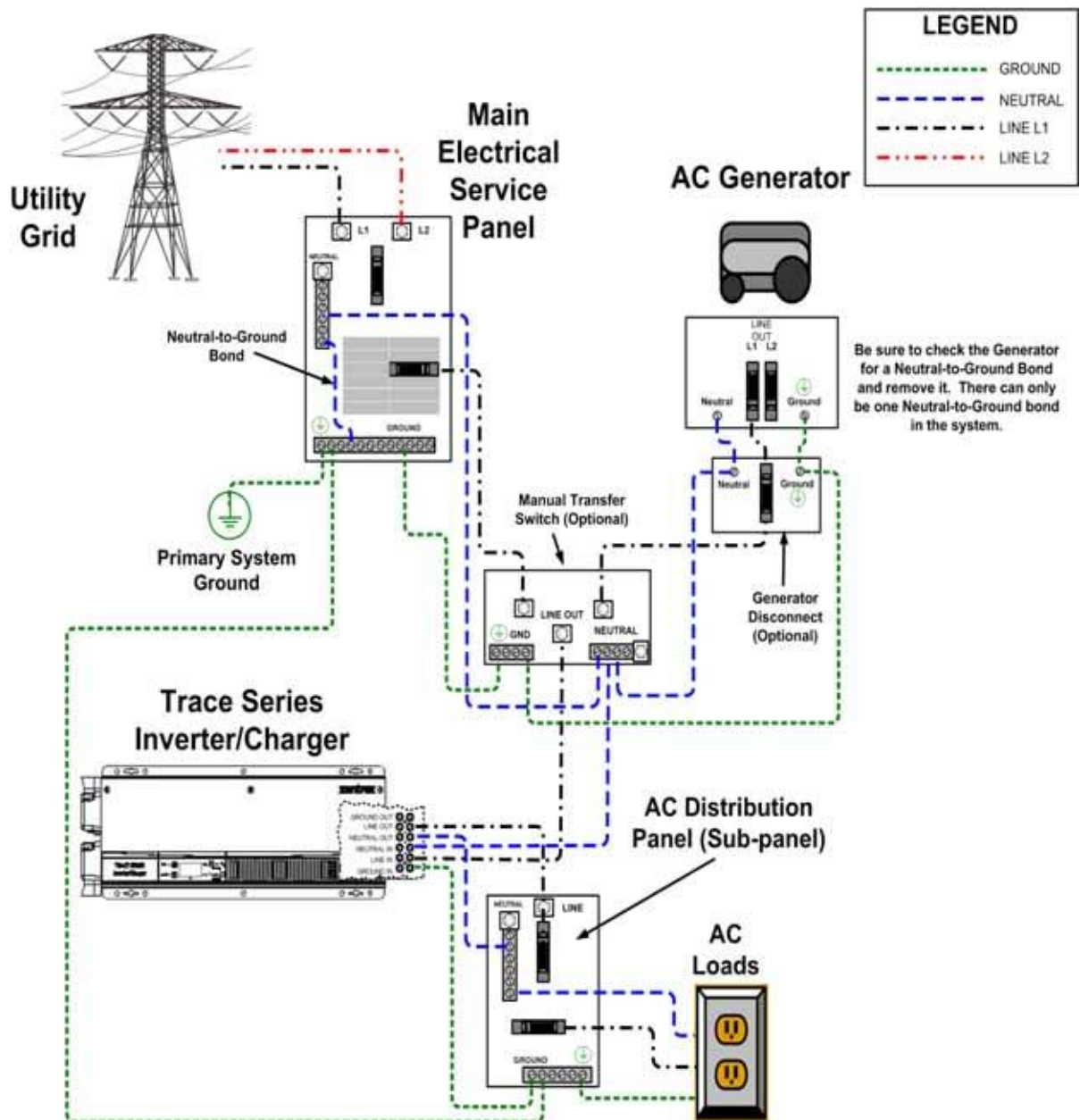

Figure 2-12 AC Wiring - On-Grid Application using a Generator

AC Wiring - Off-Grid Applications

The following diagram illustrates the AC wiring for basic configurations. Consult your system design for other possible configurations.

Important: For system configurations without generator or utility AC input, the neutral-ground bond should be placed in the inverter output load panel.

Follow the example below to complete the wiring for an off-grid application using a generator. If you have a generator with three conductor outputs (120/240 V or 240 V input) you will need to use the auto-transformer (shown as optional in the diagram) to combine the L1 and L2 lines to a single line. If you have a generator with two conductor outputs (one 120 V single phase input) you do not need to make use of the auto-transformer and your single line (L1) can be routed directly.

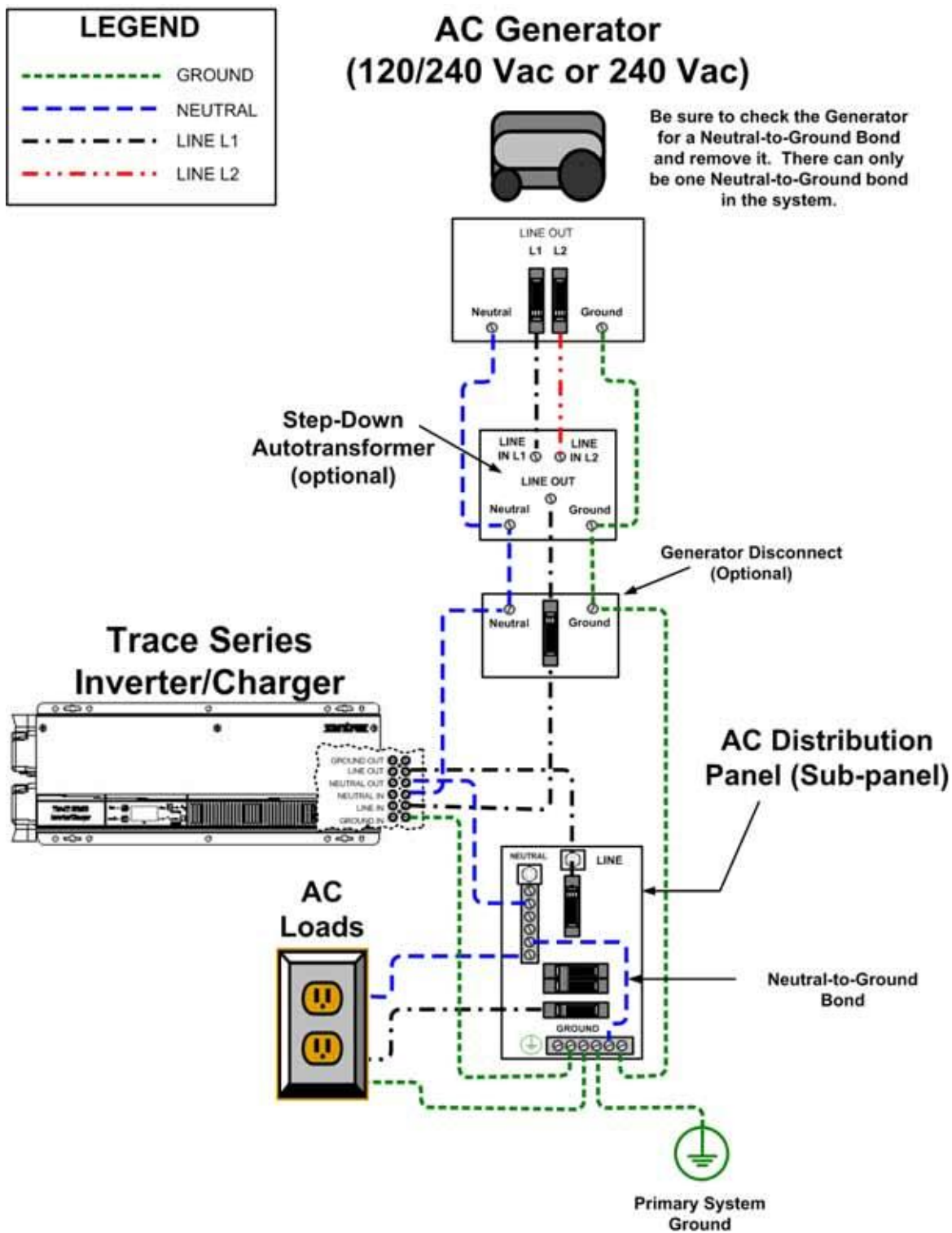

Figure 2-13 AC Wiring - Off-Grid Application using a Generator

Series Stacking

Series stacking allows the AC output of two (identical) inverters to be connected in a series configuration, providing both 120 VAC and 240 VAC, 60 Hz power for the inverter's loads.

Important: Only 120 VAC, 60 Hz models can be stacked. This option is not available for 230 VAC, 50 Hz models.

Series stacking can also be used to connect to 240 Vac only power systems providing both 120 and 240 Vac outputs. Stacking is also an excellent choice for providing power to multiwire branch circuits where stand-alone (120 VAC) inverters may require extensive house rewiring.

The included 3 ft. (0.9 m) series stacking cable is required to connect the COM ports of the two inverters to enable series stacking communication.

DC Wiring

Trace Series Inverter/Chargers can be stacked whether there is one disconnect device or two.

Important: To easily identify the Trace Series Inverter/Chargers, label one Trace Series as INVERTER 1 (L1) and the second Trace Series as INVERTER 2 (L2).

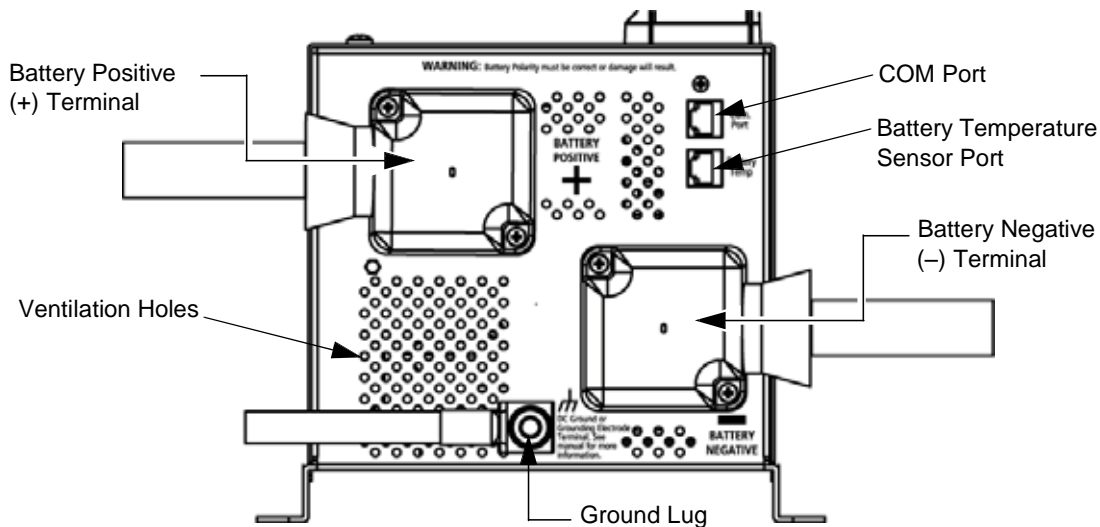

Figure 2-14 DC Side of the Trace Series

DC Wiring for Two Disconnect Devices

Xantrex recommends using two disconnect devices to keep wire to manageable sizes.



WARNING: Shock hazard

When stacking inverters, always connect the chassis of each inverter together using the chassis ground lug, otherwise a hazardous voltage may be present between each chassis.

To connect the DC wiring with two disconnect devices (see Figure 2-15):

1. Connect the negative terminals of the two Trace Series Inverter/Chargers together.
2. Connect INVERTER 1's negative terminal to the negative terminal on the battery bank.
3. Connect INVERTER 2's negative terminal to the negative terminal on the battery bank.
4. Connect INVERTER 1's positive terminal to the DC disconnect 1.
5. Connect the DC disconnect 1 to the positive terminal of the battery bank.
6. Connect INVERTER 2's positive terminal to the DC disconnect 2.
7. Connect the DC disconnect 2 to the positive terminal of the battery bank.
8. Connect the DC ground lugs of the two Trace Series Inverter/Chargers together using heavy gauge wire (according to "Battery Cable Sizing" on page 2-7).
9. Connect the series stacking cable to the COM port of both Trace Series Inverter/Chargers.

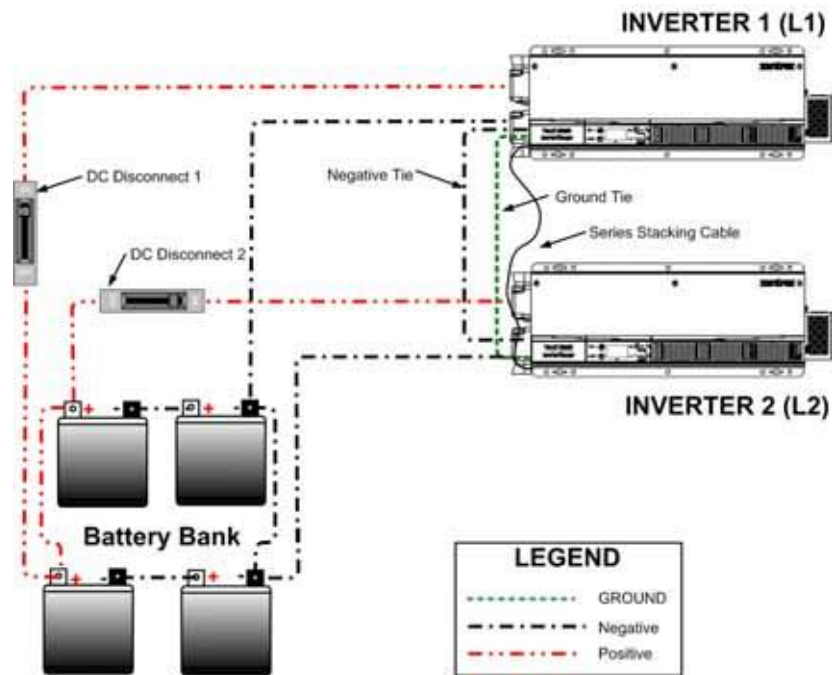

Figure 2-15 DC Wiring with 2 Disconnect Devices

DC Wiring for One Disconnect Device



WARNING: Shock hazard

When stacking inverters, always connect the chassis of each inverter together using the chassis ground lug, otherwise a hazardous voltage may be present between each chassis.



CAUTION

Installers must carefully size cables and circuit breakers. Remember that cable sizes will need to be increased in order to carry twice the current for this installation. Refer to your local electrical codes.

To connect the DC wiring with one disconnect device (see Figure 2-16):

1. Connect the negative terminals of the two Trace Series Inverter/Chargers together.
2. Connect INVERTER 2's negative terminal to the negative terminal on the battery bank.
3. Connect the positive terminals of the two Trace Series Inverter/Chargers together.
4. Connect INVERTER 1's positive terminal to the DC disconnect.
5. Connect the DC disconnect to the positive terminal of the battery bank.

6. Connect the DC ground lugs of the two Trace Series Inverter/Chargers together using heavy gauge wire.
7. Connect the series stacking cable to the COM port of both Trace Series Inverter/Chargers.

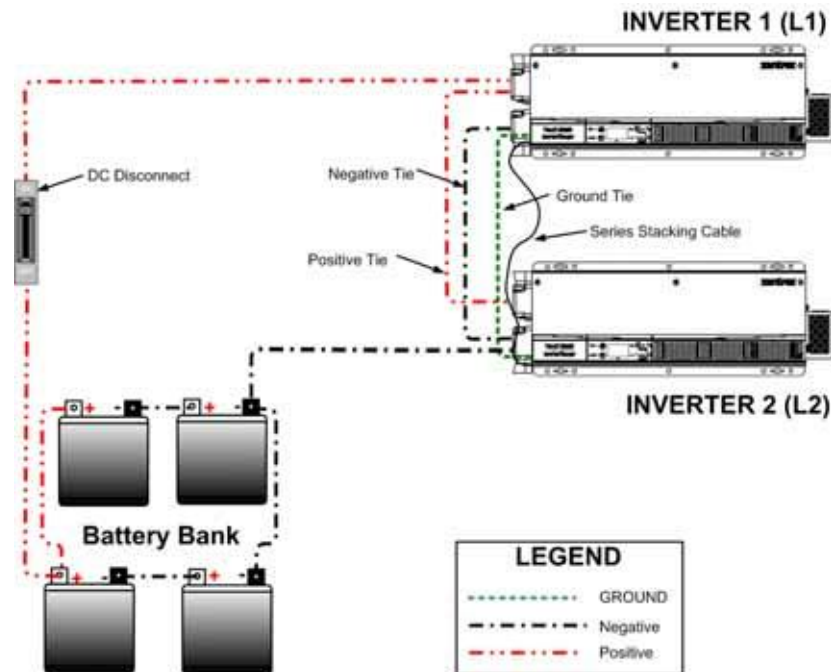

Figure 2-16 DC Wiring with 1 Disconnect Device

DC Wiring With a Conduit Box

Important: A TR-CONDUIT BOX DC Conduit Box may be required to meet code when stacking inverters, and is available for purchase wherever you purchased your Trace Series Inverter/Charger.

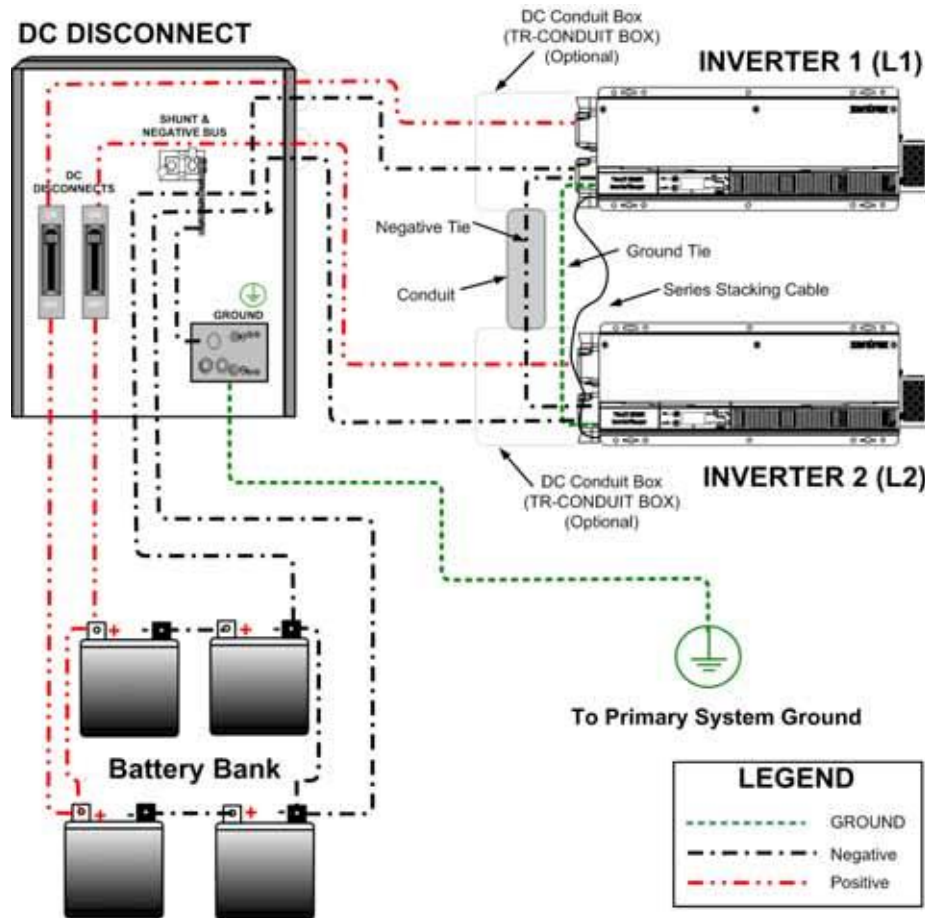

Figure 2-17 DC Wiring with a Conduit Box

Battery Connections for Stacked Inverters

When using Trace Series Inverter/Chargers in a stacked configuration, the same battery bank must be used for both inverters. To ensure even charging of the batteries, each inverter must be connected to both strings as shown in Figure 2-18.

For example:

INVERTER L1 – positive cable to string 2 and negative cable to string 1

INVERTER L2 – positive cable to string 1 and negative cable to string 2

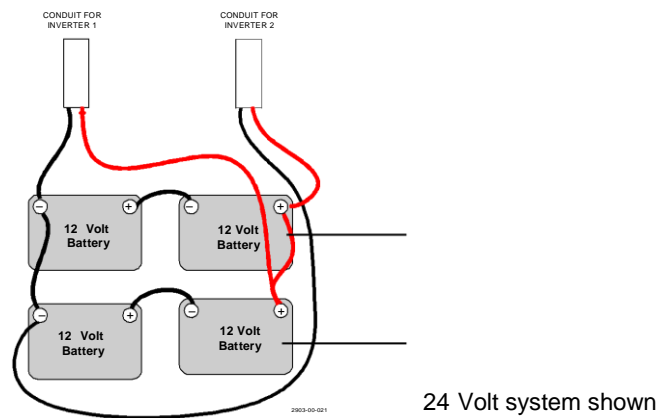

Figure 2-18 Battery Connections

AC Wiring

Series stacking is used in applications where either 240 VAC loads (or a combination of 240 VAC and 120 VAC loads) need to be powered by inverters. One inverter (INVERTER 1 - L1) receives its input from the utility's L1 line and provides one 120 VAC output; while the second inverter (INVERTER 2 - L2) receives its input from the utility's L2 line and provides 120 VAC output (180° out-of-phase). The combined out-of-phase voltages can power 240 VAC loads as well as 120 VAC loads up to the power rating of the inverters.

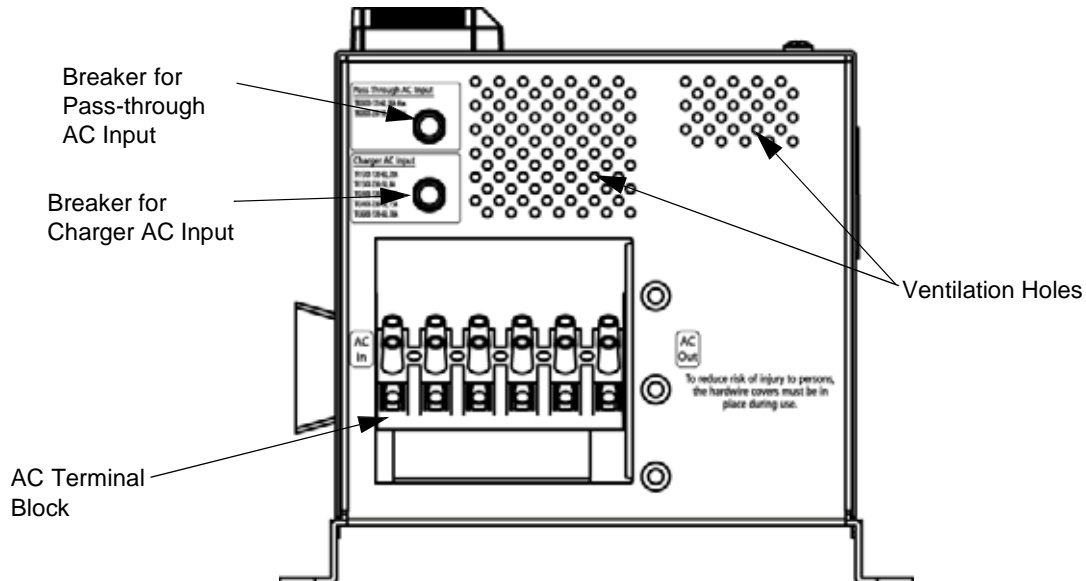

Figure 2-19 AC Side of the Trace Series

AC Input to Inverters

To connect the AC input to the inverters:

1. Connect a wire from the ground bus in the main panel to the ground IN terminal in INVERTER 1 (L1).
2. Connect a second ground wire from the ground bus in the main panel to the ground IN terminal in INVERTER 2 (L2).
3. Connect a wire from the neutral bus in the main panel to the neutral IN terminal in INVERTER 1 (L1).
4. Connect a second wire from the neutral OUT terminal in INVERTER 1 (L1) to the neutral IN terminal in INVERTER 2 (L2).
Keep this wire as short as possible.
5. Connect the line L1 from the main panel to the line IN terminal in INVERTER 1 (L1).
6. Connect the line L2 from the main panel to the line IN terminal in INVERTER 2 (L2).

AC Output from Inverters

120 VAC Source The output of each inverter provides 120 VAC. The voltage between the line outputs from the L1 and L2 inverters is 240 VAC to the sub-panel.



WARNING: Shock hazard

The ground and neutral must be bonded at one place, and only one place, in the system.

To connect the AC output from the inverters:

1. Connect the neutral wire from INVERTER 2 (L2) neutral OUT terminal to the neutral bus in the sub-panel.
2. Connect the line (120 VAC) output from INVERTER 1 (L1) line OUT terminal to the L1 main input lug in the sub-panel.
3. Connect the line (120 VAC) output from INVERTER 2 (L2) line OUT terminal to the L2 main input lug in the sub-panel.
4. Torque all connections in the sub-panel to the manufacture's specifications.

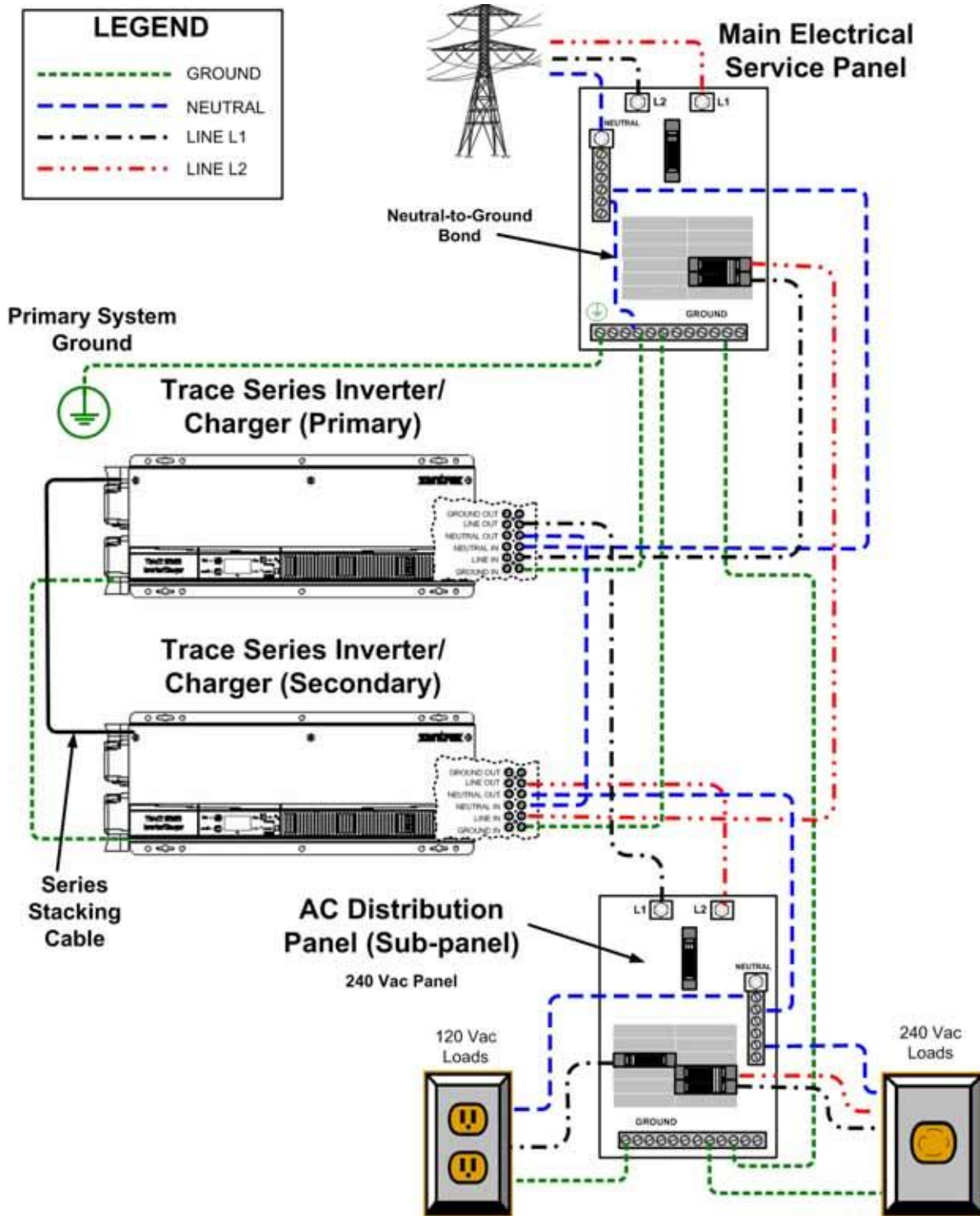

Figure 2-20 AC Wiring - On-Grid Application using Series Stacking

Testing Stacked Inverters

Important: If the search mode is used on the Trace Series, the load that “awakens” the inverters must be connected to the primary unit.

Important: Until the unit is tested, no loads must be connected to the inverter’s 120 VAC or 240 VAC output.

Start-up and Test

To start-up and test the stacked Trace Series:

1. Switch on the inverter designated as primary or INVERTER 1 (L1).
2. The inverter designated as secondary or INVERTER 2 (L2) will automatically turn on.
The inverter should be providing 120 VAC/240 VAC to the sub-panel.
3. Use a true RMS voltmeter and measure the voltage between the L1 terminal and the neutral bus in the sub-panel.
This voltage should be 120 VAC.
4. Use a true RMS voltmeter and measure the voltage between the L2 terminal and the neutral bus in the sub-panel.
This voltage should be 120 VAC.
5. Use a true RMS voltmeter and measure the voltage between the L1 terminal and the L2 terminal in the sub-panel.
This voltage should be 240 VAC.
6. Switch off one inverter (the other inverter will automatically switch off).
7. Replace all covers and panels on the inverters and sub-panel.
8. Switch on the inverter designated as primary or INVERTER 1 (L1).
9. The inverter designated as secondary or INVERTER 2 (L2) will automatically turn on.
10. Switch on the breakers in the main panel feeding the inverters.
Ensure the inverters start to charge the batteries and power the sub-panel.

The stacked inverter system is now ready for use.

Important: The input source to the stacked pair should be 240 VAC with a neutral. If only 120 VAC is supplied to one inverter (primary), the other inverter (secondary) will enable its AC transfer relay. This will disconnect the AC output power to the loads connected to the secondary inverter.

Important: Remote controls can not be used with stacked inverters.

A

Specifications

Appendix A, “Specifications” contains information about the electrical, environmental and regulatory specifications of the Trace Series Inverter/Charger.

- Table A-1 provides the electrical specifications for the Trace Series Inverter/Charger (120 Vac/60 Hz. models).
- Table A-2 provides the electrical specifications for the Trace Series Inverter/Charger (230 Vac/50 Hz. models).
- Table A-3 provides physical and environmental specifications for all models of the Trace Series Inverter/Charger.
- Information is also provided on the safety and electromagnetic compatibility specifications for the Trace Series Inverter/Charger.

Specifications

Table A-1 Electrical Specifications^a - 120 Vac/60 Hz Models

Model	TR1512-120-60	TR2412-120-60	TR1524-120-60	TR2424-120-60	TR3624-120-60
AC Nominal Input Voltage	120 Vac	120 Vac	120 Vac	120 Vac	120 Vac
Maximum AC Input Voltage	140 Vrms	140 Vrms	140 Vrms	140 Vrms	140 Vrms
AC Input Low Transfer Voltage (wide/narrow)	65/95 Vac	65/95 Vac	65/95 Vac	65/95 Vac	65/95 Vac
Frequency: ($\pm 0.04\%$ Crystal controlled)	60 Hz	60 Hz	60 Hz	60 Hz	60 Hz
Narrow Setting (Charge & Pass-through)	55—64 Hz	55—64 Hz	55—64 Hz	55—64 Hz	55—64 Hz
Wide Setting (Charge)	55—68 Hz	55—68 Hz	55—68 Hz	55—68 Hz	55—68 Hz
Wide Setting (Pass-through)	41—68 Hz	41—68 Hz	41—68 Hz	41—68 Hz	41—68 Hz
Maximum AC Input Current	50 Aac	60 Aac	50 Aac	60 Aac	60 Aac
Pass-through	30 Aac	30 Aac	30 Aac	30 Aac	30 Aac
Charging	20 Aac	30 Aac	20 Aac	30 Aac	30 Aac
Nominal AC Input Current ^b	40 Aac	48 Aac	40 Aac	48 Aac	48 Aac
Pass-through	28 Aac	26 Aac	28 Aac	26 Aac	26 Aac
Charging	12 Aac	22 Aac	12 Aac	22 Aac	22 Aac
Continuous Power (@ 25°C)	1500 VA	2400 VA	1500 VA	2400 VA	3600 VA
AC Current at Max. Charge Rate ^c	11.20 Aac	15.81 Aac	10.20 Aac	19.68 Aac	19.53 Aac
Rated Output Current	12.5 amps AC	20 amps AC	12.5 amps AC	20 amps AC	30 amps AC
Typical Efficiency	90%	92%	92%	93%	94%
AC Output Voltage (rms)	120 Vac	120 Vac	120 Vac	120 Vac	120 Vac
Max. Output Overcurrent Protection	30 amps AC	30 amps AC	30 amps AC	30 amps AC	45 amps AC
Surge Capability/Max. Output and Duration:					
Overload 10 sec Rating	3000 VA	4800 VA	3000 VA	4800 VA	7200 VA
Short Circuit 10 sec Rating	50 \pm 5 Apk	80 \pm 8 Apk	50 \pm 5 Apk	80 \pm 8 Apk	120 \pm 12 Apk
DC Current at Rated Power	157 amps	252 amps	76 amps	120 amps	186 amps
DC Input Voltage (nominal) ^d	12.6 Vdc	12.6 Vdc	25.2 Vdc	25.2 Vdc	25.2 Vdc
DC Input Voltage Range	11.0—15.0 Vdc	11.0—15.0 Vdc	22.0—30.0 Vdc	22.0—30.0 Vdc	22.0—30.0 Vdc
DC Charger Rate (Adjustable) $\pm 6\%$	10 to 70 amps	14 to 100 amps	5 to 35 amps	10 to 70 amps	10 to 70 amps
Power Factor while Charging	0.88	0.89	0.88	0.92	0.93
Tare Loss	26 W	25 W	25 W	24 W	24 W
Common Specifications:					
Voltage Regulation (max.)	104—127 Vac				
Voltage Regulation (Typical)	108—125 Vac				
Waveform	modified sine wave				
Load Power Factor (allowed)	0.8 to 1.0 (leading or lagging)				
Adjustable Load Sensing Range	5 watts minimum to 240 watts maximum				
Force Air Cooling	Variable speed fan				
Automatic Transfer Relay	30 amps maximum (non-continuous)				

a.Specifications subject to change without notice.

b.This is the minimum AC input current required, at nominal input voltage, to obtain full continuous rated pass-through and maximum battery charging while adhering to the 80% ampacity rule of North American electrical codes.

c.In bulk mode (at nominal input AC and nominal DC voltage).

d.Product may not meet voltage regulation specifications at other than "Input Nominal" at full-rated load.

Table A-2 Electrical Specifications^a - 230 Vac/50 Hz Models

Model	TR1512-230-50	TR1524-230-50	TR2424-230-50
AC Nominal Input Voltage	230 Vac	230 Vac	230 Vac
Maximum AC Input Voltage	253 Vrms	253 Vrms	253 Vrms
AC Input Low Transfer Voltage (wide/narrow)	120/180 Vac	120/180 Vac	120/180 Vac
Frequency: ($\pm 0.04\%$ Crystal controlled)	50 Hz	50 Hz	50 Hz
Narrow Setting (Charge & Pass - through)	45—55 Hz	45—55 Hz	45—55 Hz
Wide Setting (Charge)	45—68 Hz	45—68 Hz	45—68 Hz
Wide Setting (Pass-through)	41—68 Hz	41—68 Hz	41—68 Hz
Maximum AC Input Current	23 amps	23 amps	30 amps
Nominal AC Input Current	23 amps	23 amps	30 amps
Continuous Power (@ 25°C)	1500 VA	1500 VA	2400 VA
AC Current at Max. Charge Rate ^b	5.88 Aac	6.00 Aac	10.44 Aac
Rated Output Current	6.4 amps AC	6.4 amps AC	10.4 amps AC
Typical Efficiency	92%	91%	94%
AC Output Voltage (rms)	230 Vac	230 Vac	230 Vac
Max. Output Overcurrent Protection	15 amps AC	15 amps AC	15 amps AC
Surge Capability/Max. Output and Duration:			
Overload 10 sec Rating	3000 VA	3000 VA	4800 VA
Short Circuit 10 sec Rating	26.5 \pm 2.5 Apk	26.5 \pm 2.5 Apk	42 \pm 4 Apk
DC Current at Rated Power	158 amps	77 amps	121 amps
DC Input Voltage (nominal) ^c	12.6 Vdc	25.2 Vdc	25.2 Vdc
DC Input Voltage Range	11.0—15.0 Vdc	22.0—30.0 Vdc	22.0—30.0 Vdc
DC Charger Rate (Adjustable) $\pm 6\%$	0 to 70 amps	0 to 35 amps	0 to 70 amps
Power Factor while Charging	0.91	0.83	0.92
Tare Loss	23 W	21 W	22 W
Common Specifications:			
Voltage Regulation (max.)	$\pm 5\%$ (-12%, +5% TR1512-230-50 only)		
Voltage Regulation (Typical)	$\pm 2.5\%$		
Waveform	modified sine wave		
Load Power Factor (allowed)	0.8 to 1.0 (leading or lagging)		
Adjustable Load Sensing Range	10 watts minimum to 480 watts maximum		
Force Air Cooling	Variable speed fan		
Automatic Transfer Relay	30 amps maximum (non-continuous)		

a.Specifications subject to change without notice.

b.In bulk mode (at nominal input AC and nominal DC voltage).

c.Product may not meet voltage regulation specifications at other than "Input Nominal" at full-rated load.

Specifications

Table A-3 Environmental Specifications^a

Model	TR1512-120-60	TR2412-120-60	TR1524-120-60	TR2424-120-60	TR3624-120-60	TR1512-230-50	TR1524-230-50	TR2424-230-50
Trace Series only								
Dimensions ^b	8.5 in. W × 7.25 in. H × 21 in. L (216 mm W × 184 mm H × 546 mm L)							
Weight	40 lbs (18 kg)	42 lbs (19 kg)	40 lbs (18 kg)	45 lbs (20 kg)	45 lbs (20 kg)	42 lbs (19 kg)	42 lbs (19 kg)	42 lbs (19 kg)
Shipping/Packaging plus Trace Series								
Dimensions	12.4 in. W × 11.8 in. H × 26.6 in. L (315 mm W × 300 mm H × 675 mm L)							
Weight	50 lbs (22.7 kg)	52 lbs (23.6 kg)	50 lbs (22.7 kg)	55 lbs (24.9 kg)	55 lbs (24.9 kg)	52 lbs (23.6 kg)	52 lbs (23.6 kg)	52 lbs (23.6 kg)
Ambient Temp Range								
Rated Temperature Range	Invert Mode: 32 °F to 122 °F (0 °C to +50 °C)							
	Charge Mode: 32 °F to 104 °F (0 °C to +40 °C) 105 °F to 122 °F (+40.5 °C to +50 °C) 50% derating							
Storage	-67 °F to 167 °F (-55 °C to +75 °C)							
Altitude:								
Operating	15,000 feet (4570 m)							
Non-operating	50,000 feet (16800 m)							
Mounting	wall-mount with 16 in. (40.6 cm) mounting centers							

a.Specifications subject to change without notice.

b.Allows for hardware extensions such as mounting rails, DC terminals, and front panel controls.

Safety and Electromagnetic Compatibility Specifications

120 Vac/60 Hz Models	CSA 107.1 UL 1741 FCC Part 15B Class B Ind. Canada ICES-0003 Class B
230 Vac/50 Hz Models	EN50178 New EMC Directive 2004/108/EC



www.solarpowernrg.com

**#190 2188 No. 5
Richmond, BC
Canada V6X 2T1**

**604.278.7244
Toll Free: 1.877.9-4Solar**

Xantrex Technology Inc.